

2006

An investigation into microwave energy to soften scrap tire rubber aiding existing mechanical separation processes

Russell Jon Lucas
University of Northern Iowa

Let us know how access to this document benefits you

Copyright ©Russell Jon Lucas

Follow this and additional works at: <https://scholarworks.uni.edu/etd>



Part of the [Industrial Technology Commons](#), and the [Materials Science and Engineering Commons](#)

Recommended Citation

Lucas, Russell Jon, "An investigation into microwave energy to soften scrap tire rubber aiding existing mechanical separation processes" (2006). *Dissertations and Theses @ UNI*. 1304.

<https://scholarworks.uni.edu/etd/1304>

This Open Access Thesis is brought to you for free and open access by the Student Work at UNI ScholarWorks. It has been accepted for inclusion in Dissertations and Theses @ UNI by an authorized administrator of UNI ScholarWorks. For more information, please contact scholarworks@uni.edu.

Offensive Materials Statement: Materials located in UNI ScholarWorks come from a broad range of sources and time periods. Some of these materials may contain offensive stereotypes, ideas, visuals, or language.

AN INVESTIGATION INTO MICROWAVE ENERGY TO SOFTEN SCRAP TIRE
RUBBER AIDING EXISTING MECHANICAL SEPARATION PROCESSES

An Abstract of a Thesis
Submitted
In Partial Fulfillment
of the Requirements for the Degree
Master of Arts

Russell Jon Lucas
University of Northern Iowa
December 2006

ABSTRACT

This research was performed to soften scrap tires to aid in their transformation from whole tires to valuable streams of rubber and steel for reuse in industry. Actual shredded scrap rubber was used in this experiment to determine if this highly variable material could yield consistent results if subjected to volumetric heating from a magnetron emitting microwave energy.

A consumer microwave oven was used to heat this material. This oven had its control circuitry modified by using a programmable logic controller to operate the energy exposure time. The sample's surface temperature was measured utilizing a non contact infrared thermometer. All of these samples recorded hardness using a Shore A durometer and were recorded according to ASTM D2240-03 standard test for rubber property-durometer hardness. Five levels of temperature were used to record the Shore A hardness at each level. Twenty six samples completed this battery of tests to reveal how their hardness values changed with temperature.

This research has shown that samples weighing greater than 20 grams can decrease their Shore A hardness by ten percent if volumetrically heated to 100 °C. This reduction

in hardness should be reflected in efficiency gains in the mechanical separation machinery used to reduce whole tires to valuable steel and rubber reusable material.

AN INVESTIGATION INTO MICROWAVE ENERGY TO SOFTEN SCRAP TIRE
RUBBER AIDING EXISTING MECHANICAL SEPARATION PROCESSES

A Thesis

Submitted

In Partial Fulfillment

of the Requirements for the Degree

Master of Arts

Russell Jon Lucas

University of Northern Iowa

December 2006

THESIS APPROVAL PAGE

This Study by: Russell Jon Lucas

Entitled: AN INVESTIGATION INTO MICROWAVE ENERGY TO SOFTEN
SCRAP TIRE RUBBER AIDING EXISTING MECHANICAL
SEPARATION PROCESSES

has been approved as meeting the thesis requirement for the
Degree of Master of Arts.

11/1/06

Date

Dr. ~~Pecan~~ Pecan, Chair, Thesis Committee

Nov 6, 2006

Date

Dr. John T. Fecik, Thesis Committee Member

10/26/06

Date

Dr. Edward J. Brown, Thesis Committee Member

11-21-06

Date

Dr. Susan J. Koch, Dean, Graduate College

TABLE OF CONTENTS

	PAGE
LIST OF TABLES	v
LIST OF FIGURES.	vi
CHAPTER 1. INTRODUCTION AND LITERATURE REVIEW	1
Need for Research.	1
Review of Pertinent Work	3
Composition of Scrap Tires	3
Natural and synthetic rubber characteristics.	3
Microwave Energy and Volumetric Heating Defined.	8
Microwave Processes Utilized on Rubber Products.	9
Devulcanization of cured rubber with microwave energy.	9
Microwave pyrolysis of scrap tires	11
Preheating coal with microwave energy.	12
Tire Recycling Concerns.	13
Purpose and Scope of This Research	14
CHAPTER 2. EXPERIMENTAL SECTION	16
Introduction	16
Programmable Logic Control of a Household Microwave Oven	18
Pilot Run of Modified Microwave Oven	20

	PAGE
Test Procedure and Phases	21
CHAPTER 3. RESULTS	24
Introduction	24
Results from Phase One Hardness Values from Non-Metallic Trials	28
Results from Phase Two Metal Containing Samples	65
CHAPTER 4. SUMMARY AND DISCUSSION	72
Summary of Results	72
Future Work and Possible Applications.	75
Questions Needing Answers and Recommendations.	76
Conclusion	78
REFERENCES	79
APPENDIX A: INFRARED THERMOMETER SPECIFICATIONS AND AIMING DIAGRAMS.	81
APPENDIX B: PLC PROGRAM PRINTOUT	84

LIST OF TABLES

TABLE	PAGE
1. Identifying Characteristics of Various Types of Rubber.	4
2. Tire Composition by Percent of Weight.	7

LIST OF FIGURES

FIGURE	PAGE
1. Cross Section of a Radial Tire CIWMB (2003)	6
2. Photo of the modified microwave test apparatus . .	20
3. Photo of TDF pile where phase one samples originated	23
4. Photo of heat focused pocket formation	26
5. Photo of another heat induced pocket	27
6. Photo of a microwave energy focused heat pocket. .	28
7. Sample 1 with computed slope offset by + 7	31
8. Sample 4 with calculated 110 °C value.	32
9. Sample 5 maximum recorded exposure time.	33
10. Calculated slopes of the lightest samples.	34
11. Sample 10 most exposure time for weight group 17.17 g	35
12. Sample 12 has the least surface area of weight group 17.17 g	36
13. Sample 23 2 nd smallest area but heaviest of weight group 17.17 g	37
14. Sample 25 possesses the largest area and the 2 nd longest time of weight group 17.17 g	38
15. Hardness slope of average 17.17 gram samples . . .	39
16. Sample 11 is heaviest, thickest, with the least surface area of weight group 21.12 g	40
17. Sample 15 least weight and greatest exposure time for weight group 21.12 g	41

FIGURE	PAGE
18. Sample 18 aggressive slope with greatest surface area of weight group 21.12 g	42
19. Hardness slope of average 21.12 gram samples . . .	43
20. Sample 2 largest surface area with least average depth of weight group 22.74 g.	44
21. Sample 6 least weight and smallest area of weight group 22.74 g	45
22. Sample 21 had the most mass and 2 nd lowest surface area of weight group 22.74 g	46
23. Sample 22 had 2 nd least mass and 2 nd largest surface area of weight group 22.74 g	47
24. Hardness slopes of average 22.74 gram samples. . .	48
25. Sample 3 has greatest mass and almost smallest area of weight group 25.03 g	49
26. Sample 9 has most surface area for weight group 25.03 g	50
27. Sample 16 has the 2 nd highest surface area of weight group 25.03 g	51
28. Sample 26 has the smallest surface area and the least mass of weight group 25.03 g	52
29. Hardness slopes of average 25.03 gram samples. . .	53
30. Sample 7 has least surface area and most weight of weight group 26.57 g.	54
31. Sample 17 has the greatest surface area and 2 nd highest weight of weight group 26.57 g	55
32. Sample 19 has almost the smallest surface area and least weight of weight group 26.57 g	56

FIGURE	PAGE
33. Hardness slope of average 26.57 gram samples . . .	57
34. Sample 13 with calculated 90 and 110 °C values in weight group 32.83 g	58
35. Sample 20 shown with computed 90 and 110 °C values in weight group 32.83 g	59
36. Sample 24 with largest surface area and mass for weight group 32.83 g	60
37. Hardness slope of average 32.83 gram samples . . .	61
38. Sample 8 with calculated 90 and 110 °C values for weight group 44.86 g	62
39. Sample 14 has largest surface area and least weight of weight group 44.86 g	63
40. Hardness slope of average 44.86 gram samples . . .	64
41. Photo of wire sample 1 weighed 11.02 grams exhibited the most flame of phase two samples. . .	66
42. Photo of wire sample 2 weighed 240.51 grams no burning witnessed.	68
43. Photo of wire sample 3 weighed 285.13 grams with minimal flame events	69
44. Photo of wire sample 4 weighed 27.05 grams with some burning	70
45. Composite of sample weight groups of over 20 grams hardness percent change.	74

CHAPTER 1

INTRODUCTION AND LITERATURE REVIEW

Need For Research

According to Amari, Themelis, and Wernick (1999), an accumulation of waste tires and scrap rubber waste is posing a serious threat to the environment. In addition, Ahmed, Klundert, and Lardinios (1996) said tires take over a century to disintegrate at ambient temperatures and tire piles can trap water providing breeding grounds for mosquitoes and bacteria.

In 1996 alone, 266 million tires were scrapped in the United States, a quarter of this amount ended up in landfills or junkyards (Amari, et al., 1999). Beck (2005) said stockpiled tires can result in dangerous and difficult to extinguish fires that can burn for long periods of time. These fires can contaminate groundwater and decrease air quality.

Shredded radial tires as practiced when recycling, create problems with rubber reclamation and recycling methods because the steel is costly to remove (Amari, et al., 1999).

Several countries both industrial and developing are confronted with this problem of tire waste accumulation.

Ahmed, et al.(1996) suggested these steps:

1. Reduce the number of tires becoming waste by engineering a longer life tire or by using other forms of transportation instead of personal automobiles.
2. Reuse tires for retreading processes or the whole tire as artificial reefs or bridge building (Beck, 2005).
3. Recycle tires into value added products that use the waste tire's properties for new applications.
4. Use them in civil engineering projects as tire derived aggregates in road bed construction, septic leach fields, and compositing fill.
5. As tire derived fuels (TDF) in cement kilns, waste to energy facilities, and electric utility coal fired power plants.
6. Recovery of raw material through pyrolysis or the decomposition of the tire into raw constituents through the use of very high temperatures within an evacuated chamber.
7. Shred and landfill or place in a monofill.

In reviewing the literature and conversations with Froelich, D. (personal communication, March 3, 2006) and Heidershiet K. (personal communication, February 10, 2006), current tire recycling processors, in the "real" recycling world the greatest focus is on finding markets for their products. The ability to deliver more products to their existing markets would benefit their profitability. Steps 3 through 5 above encompass the vast majority of their operations.

Review of Pertinent Work

Composition of Scrap Tires

Natural and synthetic rubber characteristics. Ahmed, et al. (1996) stated that natural rubber (NR) is made from a substance known as caoutchouc or latex, which is sap from a rubber tree officially called *Hevea Brasiliensis*. The chemical name for natural rubber is polyisoprene. Ahmed, et al. (1996) also said that natural rubber is opaque and softer when heated above 50°C and at higher temperatures becomes tacky and less elastic finally liquefying at 190 - 200 °C.

Various types of synthetic rubber can be produced through polymerization of mineral oil, such as styrene-butadiene-rubber (SBR), ethylene-propylene (EP), butyl

(IIR), and nitrile rubbers (NBR). See Table 1 for identifying characteristics of various types of rubber.

Table 1
Identifying Characteristics of Various Types of Rubber

CHARACTERISTICS	NR	SBR	BUTYL	NITRIL
Drips when exposed to flame			XX	
Crackles when exposed to flame				XX
Sticky combustion surface	XX		XX	
Dry combustion surface		XX		XX
Hot flame	XX	XX		XX
Quiet flame			XX	
Weak soot			XX	
Strong soot	XX	XX		XX

Source: Ahmed, et al. (1996)

Carbon black is used as filler and microwave energy absorber. Carbon black is used as filler in tire construction because it acts to increase the overall strength, elasticity, and resistance to abrasion of the rubber compound (Ahmed, et al., 1996).

Atwater and Wheeler (2004) state all graphitized carbon blacks are strongly susceptible to microwave heating at 915 and 2,450 MHz, the two most commonly used

frequencies for microwave appliances. Ganchev, Bhattacharyya, Bakhtiari, Qaddoumi, Brandenberg, and Zoughi (1994) have shown that increasing the carbon black percentage within an ethylene propylene diene (EPDM) rubber compound also increases the real and imaginary parts of rubber dielectric constant, thus allowing the material to be more susceptible to microwave energy as its dielectric constant increases. Carbon black was a key component when Lester and Kingman (2004) used microwave energy on Thoresby coal for 2 seconds at a power level of 8.5 kW to show that the coal could be crushed 20% better than untreated coal over various size ranges tested.

California Integrated Waste Management Board (CIWMB) (2003) says radial tire makeup consists of natural rubber, synthetic rubber, carbon black, steel, and miscellaneous (fabric, fillers, accelerators, stabilizers) in varying percentages by weight. Refer to Figure 1 for the location of typical tire components.

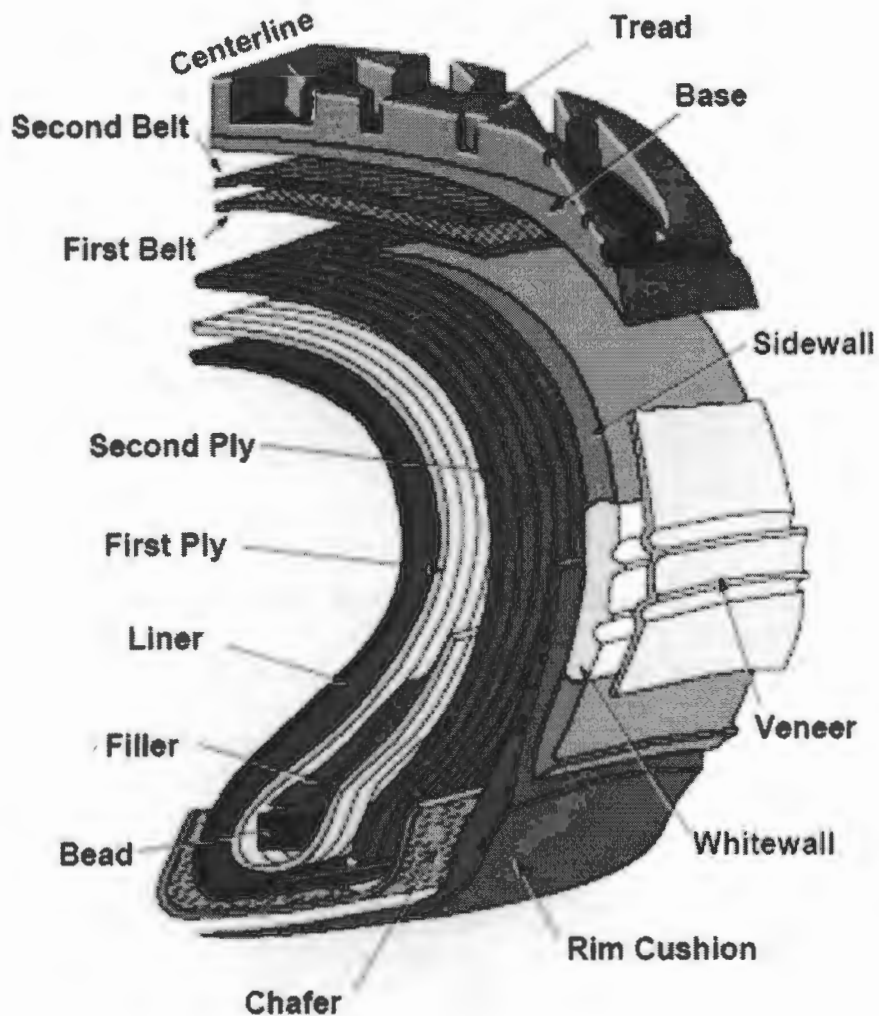

Source: The Cooper Tire & Rubber Company, 2003
www.coopertire.com/us/en/information/info-construction.asp

Source CIWMB (2003)

Figure 1 Cross Section of a Radial Tire.

The chafer, first and second ply's contain the fiber components of the tire's construction. Fiber can consist of one or more strands of polyester, nylon, or aramid

fibers. Synthetic rubbers are found in the whitewall, veneer, and sidewall. Natural rubbers are mainly present in the rim cushion, liner and tread layer. First and second belts are made of fine gauge tire belt wire while a thicker gauge steel is used to produce the bead wire. Bead steel conforms to AISI 1070 or better. Both bead and belt steel can be coated with copper, bronze, or brass to promote adhesion with the tread or to protect it from corrosion (CIWMB, 2003).

The bead and belt wire make up the entire steel content for a radial tire. Refer to Table 2 for specific percentage valuations.

Table 2
Tire Composition by Percent of Weight

MATERIAL	PASSENGER TIRES (% BY WEIGHT)	TRUCK TIRES (% BY WEIGHT)
Natural rubber(NR)	14%	27%
Synthetic rubber	27%	14%
Carbon black	28%	28%
Steel(belt & bead)	15%	15%
Misc (fabric, fillers, accelerators, antiozonants)	17%	16%

Source: Beck (2005)

All tire samples used in this study are shredded passenger car tires. These car tires represent eighty percent of the tire recycler's incoming material. They are also the least marketable commodity due to their high fiber and synthetic rubber content. They are primarily used as a tire derived fuel (TDF) for power plants and cement kilns. (K. Heidershiet, personal communication, February 10, 2006)

Microwave Energy and Volumetric Heating Defined

Microwave energy and how it causes volumetric heating are defined as follows:

Gallawa (2006) said that microwave energy is composed of very short waves of electromagnetic energy in the same band of frequencies used in radio and television broadcasting. This is termed non-ionizing radiation as opposed to X ray, gamma and cosmic rays which can caused molecular damage due to their ionizing radiation.

Gallawa (2006) described microwave heating this way:

So the heat is produced directly in the food, but the food is not cooked, as is commonly believed, from the inside out. Actually, the cooking begins just beneath the outer surface and from there inward and outward, with the majority of the energy being expended in the outer layers. The rate and degree of heating depend on the depth and density of the food, as well as its ability to conduct heat. Because the microwave energy is changed to heat as soon as it is absorbed by the food, it cannot make the food radioactive or contaminated. (www.gallawa.com/microtech/howcook.html)

Appleton, Colder, Kingman, Lowndes, Read (2005)

defined dielectric material as;

Materials that absorb microwaves are known as dielectrics and possess two important properties: They have very few free charge carriers. When an external electrical field is applied, there is very little charge carried through the material matrix. The molecules or atoms comprising the dielectric exhibit a dipole movement. (p. 86)

Further, Appleton et al. (2005) defined volumetric heating as;

When a dielectric is placed within an alternating electric field (i.e., a microwave cavity), the dipoles within the material attempt to realign themselves according to the applied field. The dipoles in the material exposed to the alternating electromagnetic field realign themselves approximately 2.5 billion times per second (for a microwave frequency of 2.45 GHz). This generates internal friction, causing the microwave receptive material to heat up. (p. 86)

Now that we know how dielectric material is heated by microwave energy, let us examine how microwave processes have been used on rubber compounds.

Microwave Processes Utilized on Rubber Products

Devulcanization of cured rubber with microwave energy.

Beck (2005) remarked that "The development of devulcanizing technology has been ongoing for at least 25-30 years without commercial success."

There are many obstacles involved in using microwave energy to devulcanize rubber. Chief among them is the vast

cocktail of rubber formulations that exist with every tire made and the amount of preprocessing necessary in size reduction and filtering to have a clean enough finely sized (crumb) rubber to introduce into the devulcanizing process (Beck, 2005).

Laboratory experiments strictly control the rubber formulation, cure it, and process it into crumb rubber then place this clean crumb rubber into equipment for devulcanization. The resultant material is then recurred and its physical characteristics are compared to virgin rubber cured once (Yun and Isayev, 2003).

Successful implementation to a pilot and pseudo commercial level has been achieved by the use of a twin screw extruder applying heat and pressure then squeezed through a die where the material is exposed to ultrasonic energy breaking the sulfur to sulfur and carbon to sulfur cross links (Yun and Isayev, 2003).

No laboratory scale devulcanization experiment performed on shredded waste tires has been found in the search through the literature. CIWMB (2004) stated it this way:

Clearly, the need for testing of waste tire devulcanization technologies is substantial. These tests should be based on a variety of waste tire feedstocks in order to identify the technical barriers to the technologies (and, therefore, resulting cost barriers). Circumstantial and anecdotal evidence indicates significant technical and economic barriers to devulcanization of waste tire rubber. (p. 59)

Further, CIWMB (2004) said about devulcanizing waste tires:

When a tire is size reduced, the ground rubber becomes a mixture of all types of materials with different properties. Optimizing devulcanization processes is difficult when materials of disparate properties go into the feedstock for the process. Thus, the properties of the resultant devulcanized product are compromised. (p. 60)

Microwave pyrolysis of scrap tires. Ahmed et al.

(1996) quipped that pyrolysis of rubber waste is heated in an oxygen free environment causing decomposition into constituent parts and gases.

Burnett (2003) constructed and operated a pilot plant that used microwave energy to reduce scrap tires at Environmental Waste International test facility from 1994 to 1997. This pilot plant processes up to 300 tires per

day with conceptual design for a 6,000 tires per day commercial scale plant.

The feasibility of this process on a commercial scale offered by Beck (2005);

Although pyrolysis has had many proponents and many incarnations over the past decade, it remains an emerging technology. The most recently developed technologies are variations on the older versions that proved unsuccessful. (...)While improvements have been made, it remains unclear whether any of these technologies is ready for large scale commercial development in the U.S. (pp. 8-9)

Ahmed et al. (1996) stated;

Finally, it should be emphasized that there are few successful examples of operating pyrolysis plants in the world. The products appear so attractive that attempts are continually being made to get this technical approach going, but they consistently fail either financially or technically. The plants which are in operation seldom meet either technical or economic projections, and are often idled during or immediately after their shakedown period. (p. 58)

Preheating coal with microwave energy. Some success at the pilot stage is awaiting further commercial development. This information has some bearing on this current research due to coal's high carbon black content and tire derived fuels are often used as a replacement for coal (Lester and Kingman, 2004).

Tire Recycling Concerns

From the NY tire report Beck (2005);

According to the Rubber Manufacturers Association, on average, about 84 percent of scrap tires are passenger car tires, about 15 percent are light and heavy truck tires, and about 1 percent are heavy equipment, aircraft and other off-the-road vehicle tires. (p. 2-2)

Two major Iowa scrap tire processors, K. Heidershiet (personal communication, February 10, 2006) and D. Froelich (personal communication, March 3, 2006) said eighty percent of their scrap tire markets are car tires which have an unfavorable reputation in the recycling world mainly due to their construction. They also revealed that due to the fiber and non-black synthetic rubber sidewalls of most tires, their use is destined to the TDF piles that are the least economically viable products produced by them. The other twenty percent is comprised of truck tires which have higher steel and natural rubber content with little or no fiber.

Uniform color crumb rubber in 40 mesh or smaller size has the greatest market potential as long as it is 99% free of steel and fiber (Sandoval, 2004). Current tire size reduction equipment is capable of removing the steel at that high rate, however, passenger car tires with very high

fiber content throughout its structure prevents the air classifiers and other separation equipment from attaining a high fiber free rate. A process to aid the current size reduction equipment in producing a cleaner crumb rubber from passenger car tire inputs would greatly increase the market supply and stability of these commodities.

Purpose and Scope of This Research

It is the purpose of this research to use microwave energy as volumetric heating process on scrap tires to improve the efficiency of size reduction equipment in current recycling practice. Further, this research will determine the sub curing temperature at which the tire rubber will show the lowest Shore A hardness value. By carefully controlling the amount of microwave energy released into a sample through exposure time and process temperature monitoring, an ideal softness of rubber can be achieved without adverse affects to its physical properties. The softness should translate into less mechanical force needed to separate the tire wire and fiber from the rubber. As size reduction equipment efficiencies go up so should its ability to produce cleaner supplies of crumb rubber, steel and fiber. Thereby increasing the market demand for this high quality recycled material.

By using samples taken from commercial tire shredding equipment, this research should point to a realistic approach toward applying the experimental results to a pilot and finally a commercially viable production process.

CHAPTER 2

EXPERIMENTAL SECTION

Introduction

As a life long advocate of applying technology to solve problems, this experiment and study in general just shows what can be done with readily available technology used in a novel way to solve not just one but many problems.

A household microwave oven is the primary microwave energy source for this experiment. An electrical outlet that has a voltage of 120 VAC and a power rating of 650 Watts is converted by a transformer from its primary windings to its secondary high voltage (HV) windings, a HV diode and capacitor coupled to the secondary windings provided power to the magnetron tube. The magnetron tube emits a stream of electrons at a frequency of 2,450 MHz down a waveguide to the resonant chamber (Gallawa, 2006).

Rubber is substituting food in this experiment. While a small percentage of tire composition may have water molecules due to the curing process that produced the tire, this experiment is not relying on water molecules to be the heating catalyst, rather, the carbon black component of the

tire construction will be the absorber of microwave energy. Many studies have shown that carbon black powder when exposed to microwave energy achieves high temperature levels very quickly.

Still other studies show that natural rubber and synthetic rubber both contain carbon black powders in their formulations also respond well to microwave energy in the form of temperature peaks. Appleton et al. (2005) said the following about tire wire, "Reflecting materials such as metals possess a property such that the incident waves reflect off the material surface."

Fiber cords within the tire seem to be transparent to microwave energy based on the literature reviewed.

Therefore, rubber should absorb the majority of the microwave energy with potentially higher temperature concentration near the encased steel and rubber boundary layers.

Scrap tire rubber has carbon black within its make up, however, when added into a mixture of other components should result in a linear temperature response to the microwave energy (Roussy, Mercier, Thiebaut, & Vaubourg, 1985). It is this expected linear response that will enable the control of this volumetric heating process.

Without a linear response, cascaded temperature elevations within the sample will lead to an exothermic reaction (Roussy et al., 1985). Linear temperature response is vital due to the control variable measuring the surface temperature of the sample with an infrared (IR) temperature sensor.

Programmable Logic Control of a Household Microwave Oven

The power control system in a typical microwave oven consists of a power cord fused with the system current flowing through the door and fan interlock switches to an electromechanical timing circuit and finally a start contact (Gallawa, 2006). Timing control is by an alternating current AC synchronous motor which uses the 60 Hertz frequency of the line voltage to move mechanical gears and provide for minutes by moving a set of gears 3 600 times. 60 cycles per second times 60 seconds in a minute equals 3 600. The accuracy needed in this experiment requires a more robust control scheme.

Consequently, Model KMO-13G KMC branded household microwave oven's original control circuit has been replaced with an Allen Bradley programmable controller. This controller consists of a separate power supply attached to a four slot backplane rack from which the controller module

with one thermocouple input module and one 120V AC 16 point input module and one relay 16 point output module are all inserted into this rack.

The idea to use a non contact sensor was highlighted in the Bosisio, Dallaire, and Phromothansy (1977) work on non contact sensors in a microwave chamber. The writer has worked with non contact IR temperature sensors prior to this study. The process variable uses a handheld laser point Fluke IR temperature sensor. This IR sensor is aimed at many points across the surface of the sample with a max temperature recorded on its LCD display. Refer to Appendix A for IR sensor specifications and aiming instructions.

The small logic controller SLC 5/03 is programmed with Rockwell Automation software on a personal computer. This program is transmitted or downloaded to the SLC 5/03 through a RS485 communication link. The program will determine when the magnetron will receive power based on the preset value entered for the heat elapse timer. The heat preset value can be modified at any time with the use of a laptop computer communicating with SLC 5/03. Refer to Appendix B for a printout of the ladder logic used to control the microwave. Figure 2 shows the modified microwave test apparatus.

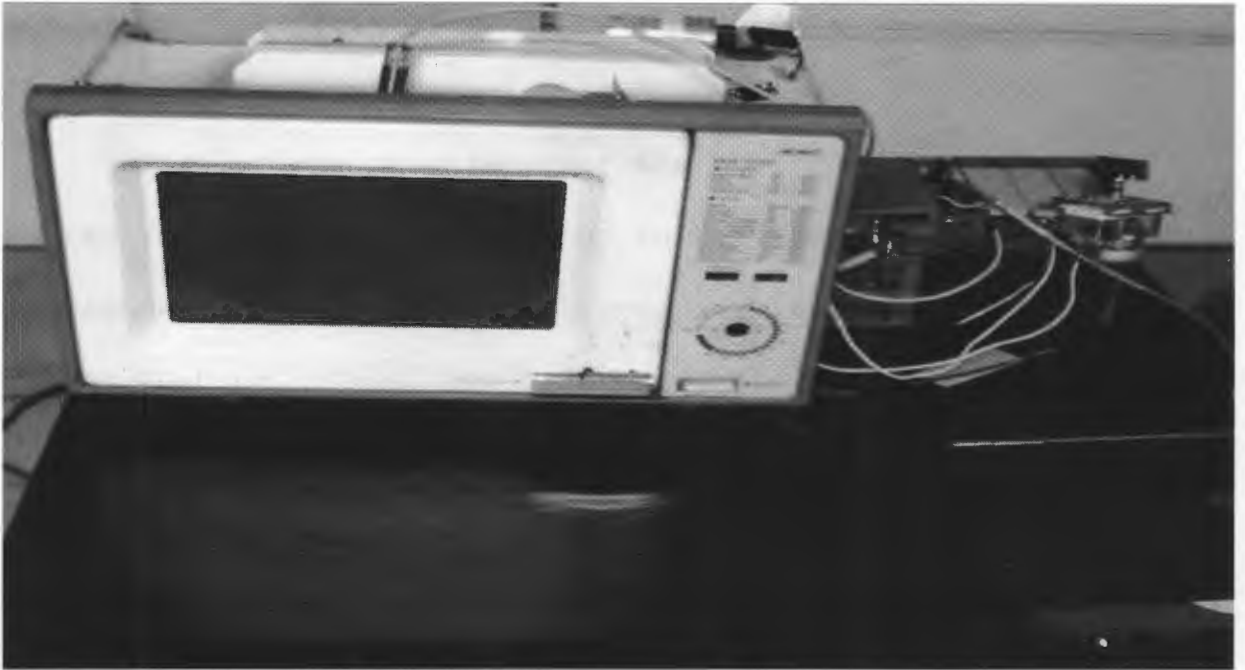

Figure 2 Photo of the modified microwave test apparatus.

Pilot Run of Modified Microwave Oven

A pilot run was conducted using water in a ceramic mug to verify the temperature accuracy of a separate IR temperature sensor mounted within the cook chamber. The temperature was correlated with a J type thermocouple reading of the water on a continuous basis. The handheld IR temperature sensor was also used to record readings.

This run established the accuracy of the temperature sensor as well as the process controls for this microwave. It also pointed out any flaws in the choice of sensors or

control methodology. Pilot run has been successfully completed, this testing equipment is considered reliable to conduct the experiments.

The pilot run revealed that the cook chamber mounted Raytec IR sensor did not hold up to the microwave energy bombardment of its thermopile rendering it non-effective during heating. Thus, the Fluke handheld IR temperature sensor was used exclusively for reading and recording the surface temperatures of the samples. Pilot run also revealed that any metal exposed to air will immediately produce electrical arcing for as long as the magnetron is emitting electrons. Arcing occurs if the metal has sharp edges or points and gaps that serve to concentrate the electrons. The microwave has a painted metal removable cooking platter. No problems were observed with this platter, however, a sharp surface imperfection on the platter concentrated enough energy to burn a depression in one of the samples during testing. The sample was not destroyed and testing resumed.

Test Procedure and Phases

The experiment followed ASTM D2240 - 03 Standard Test Method for Rubber Property - Durometer Hardness requirements for sample size and methodology. A Shore A

hardness durometer in the form of a handheld gauge was used exclusively for hardness readings. D2240-03 states that manual operation with a handheld durometer will cause variations in the results obtained. Every effort was made to insure the repeatability of the readings given the nature of the recording apparatus. D2240-03 requires a minimum sample thickness of 6 mm with five readings made 6 mm apart on the sample surface, these readings must be recorded within 1 ± 0.1 second (S) of cessation of indenter travel. These five readings can be used to calculate the arithmetic mean or the median of sample readings. Arithmetic mean calculation was used on all samples which recorded hardness values.

Phase one recorded hardness values at six temperature levels for twenty six samples. Phase two has written descriptions and audio visual recorded phenomenon of four metal containing samples that were exposed to microwave energy. Figure 3 reveals the TDF pile where all phase one samples originated.



Figure 3 Photo of TDF pile where phase one samples originated.

CHAPTER 3

RESULTS

Introduction

Twenty six samples were chosen based on their average thickness being equal to or greater than 6mm and metal free composition. Once chosen, each sample shore A hardness was determined at ambient temperature approximately 25 °C. Pilot testing revealed that sample thickness greatly affected which microwave exposure time interval should be used. The use of four or eight second exposure periods was determined most effective at gradually raising the average surface temperature of the test samples. Generally, the thicker the sample or non-uniform thickness of the sample would cause one to choose the four second interval. The incorrect exposure time would cause hot pockets to form within the sample rendering further testing ineffective. Figures 4, 5, and 6 show formation of heat focused pockets. Once these pockets form any further microwave energy exposure causes an immediate flare up or smoking of the sample.

Samples were heated in twenty degree Celsius steps starting from 30 °C up to 110 °C. Due to the variability inherent in these samples, a twenty degree surface

temperature window was used to compensate for surface cooling during hardness readings.

The first phase involved twenty six metal free samples with average thicknesses between 6 mm to 24 mm. The second phase of these trials involved four samples that contained metal. No attempt was made to determine their hardness as three of the four samples exhibited burning. The intent of this phase was to ascertain how sparking or fire affected these samples. Descriptive findings in written and audio-visual format highlight the findings of this phase.



Figure 4 Photo of heat focused pocket formation.



Figure 5 Photo of another heat induced pocket.



Figure 6 Photo of a microwave energy focused heat pocket.

Results from Phase One Hardness Values from Non-Metallic
Trials

The twenty six test specimens were separated into eight groups by weight. At each weight level the samples were classified according to their average thicknesses. And lastly, these specimens were ranked on their apparent surface area differences.

These variables of mass in grams, thickness in millimeters, energy exposure time, and subjectively

compared surface areas all have significant bearing upon the results. These variables affected the Shore A hardness percent change versus the temperature change for each trial. Specifically, as the weight of the samples increased the percent change in hardness loss increased. The second lightest group that averaged 17.17 g lost an average of 10.36 % while the heaviest sample group at 44.86 g lost an average of 19.97 % of the initial hardness values. Far more interesting was the phenomenon of increased mass caused a corresponding decrease in energy exposure time needed to complete the trials. For instance, the minimum weight samples needed approximately 409.6 s of exposure time while the largest specimens only required 66 s! Large surface areas on low mass subjects required the most energy exposure times. Even for samples that weighed within one to two grams of each other, generally, the specimen with the largest surface area required more exposure time to complete these trials. Within a weight class, the smaller the surface area combined with the largest average thickness of specimen generally resulted in the greatest decrease in percentage of hardness values over the measured temperature range.

The data for all specimens will be presented in graphical form. Every effort was made to preserve the validity of the data but some samples did not complete the full battery of tests. For those samples that Did Not Finish (DNF), a calculated value is given for the missing values based on the slope of the existing data points. All of the data points are plotted along with a calculated slope of the as recorded data. Often this slope has a b term intercept to offset the computed slope to fit the actual data values. This data will show that the lower or no b term represented the best fit of the slope to the actual data recorded.

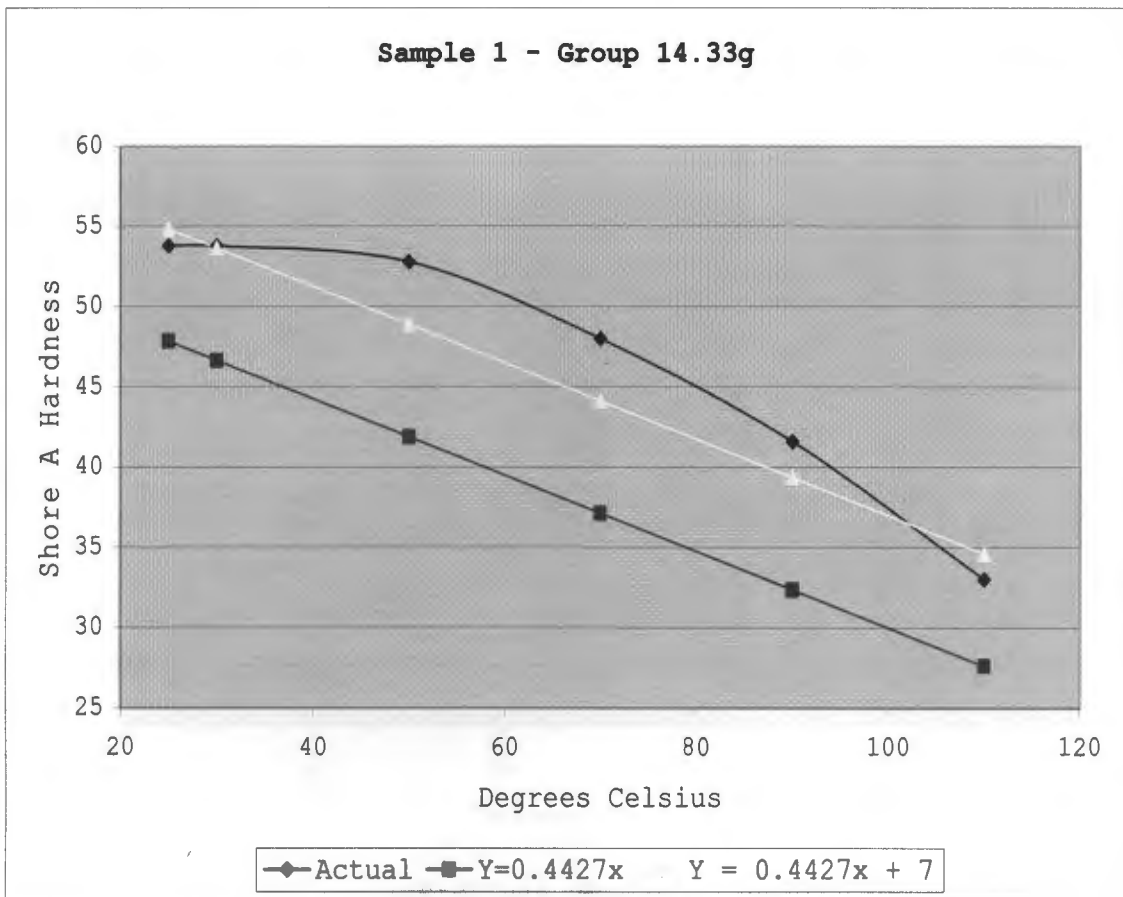

Figure 7 Sample 1 with computed slope offset by + 7.

Figure 7 shows sample 1 which was the lightest and thinnest of all samples. Most samples had either 4 or 8 second periods of magnetron energy exposure, this sample being the first and the lightest had multiple 30 second periods of exposure since surface temperatures were cooling off quickly making it difficult to achieve higher surface temperatures.

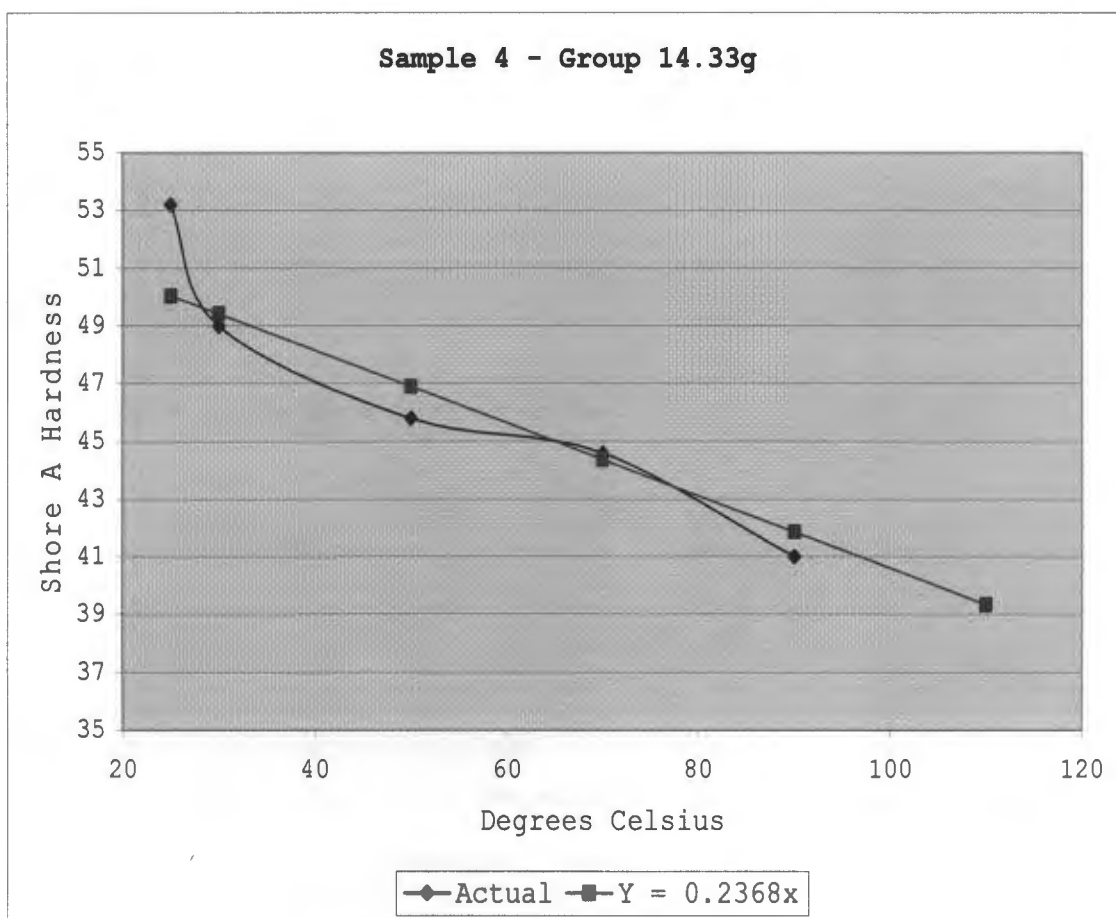

Figure 8 Sample 4 with calculated 110 °C value.

Sample 4 in Figure 8 DNF the reading at 110 °C instead a calculated slope determined the value for this sample at that temperature. 345 s were logged for sample 4 before a hot pocket formed and prevented further testing to reach the maximum temperature level.

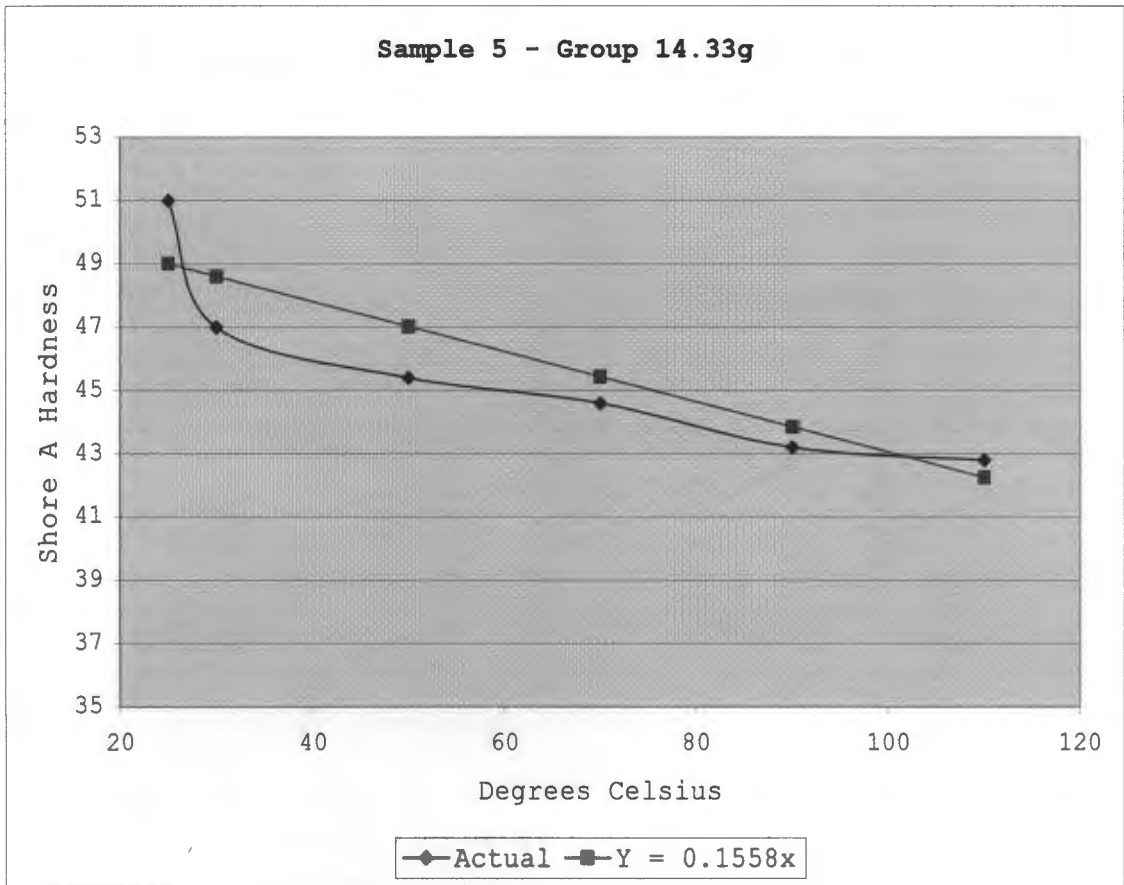

Figure 9 Sample 5 maximum recorded exposure time.

Figure 9 shows sample 5 which had the largest surface area of this group and recorded the highest energy exposure time of all twenty six samples at 582 s. It is interesting to note at higher temperatures the sample is cooling down depicted by crossing the slope line at 100 °C.

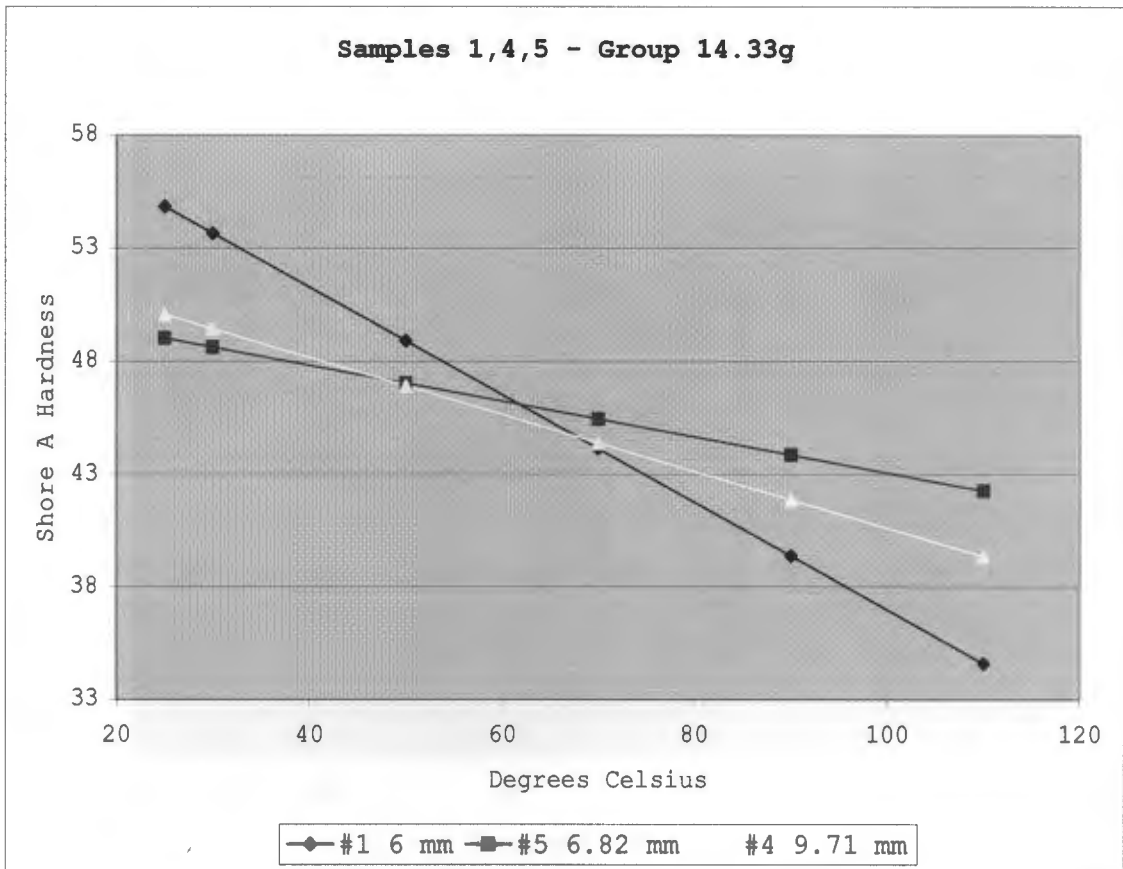

Figure 10 Calculated slopes of the lightest samples.

Sample 1 computed slope with offset from Figure 7 is shown in the composite graph depicted in Figure 10 that shows calculated slopes from samples 4 and 5 as well. Figure 10 includes these samples in one graph since these are the lightest weight group of all twenty six samples recorded. Average time to complete trials for these samples was 409.6 s.

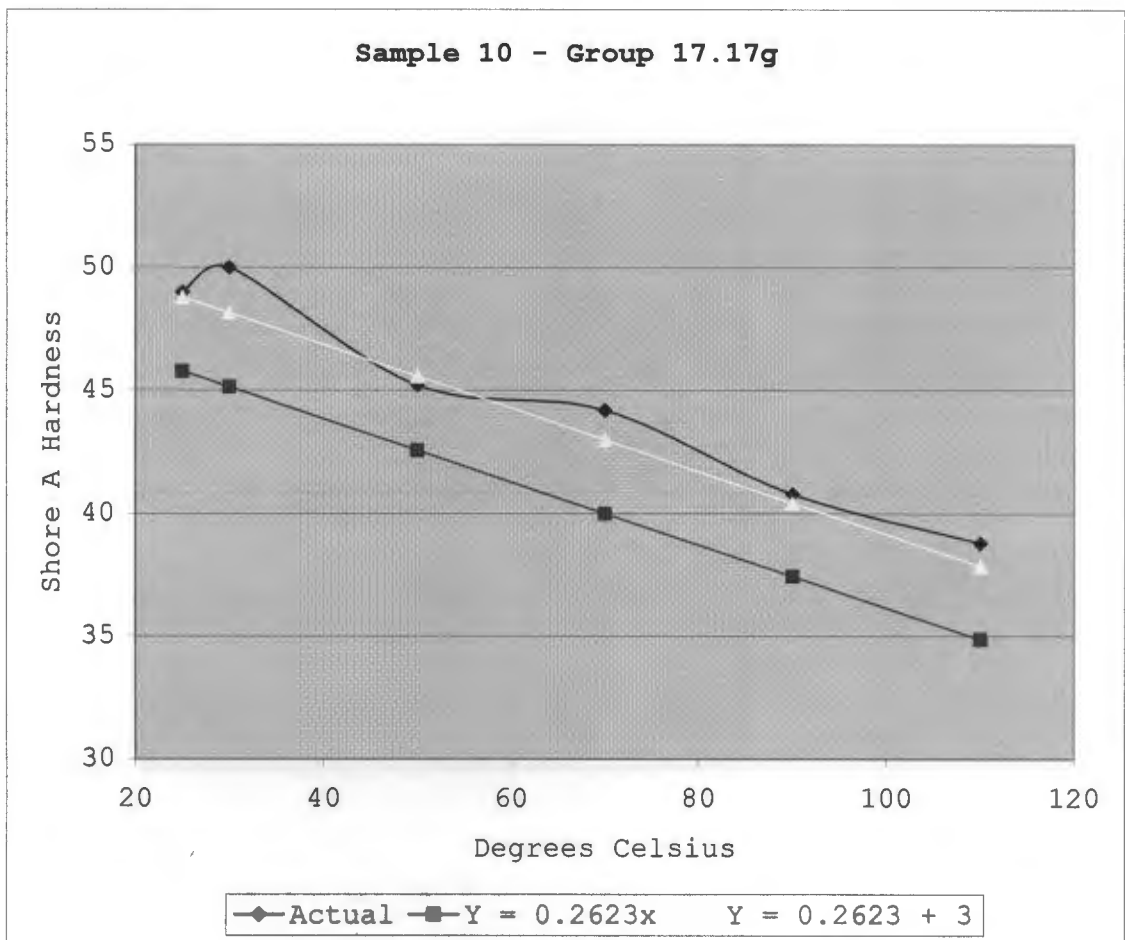

Figure 11 Sample 10 most exposure time for weight group 17.17 g.

Figure 11 shows sample 10 with a high offset value added to its slope suggesting that this may not be the most statistically valid for this data. Sample 10 recorded a time of 192 seconds to complete the set of trials. The increase in hardness shown at 30 °C is due to an inconsistent hardness reading.

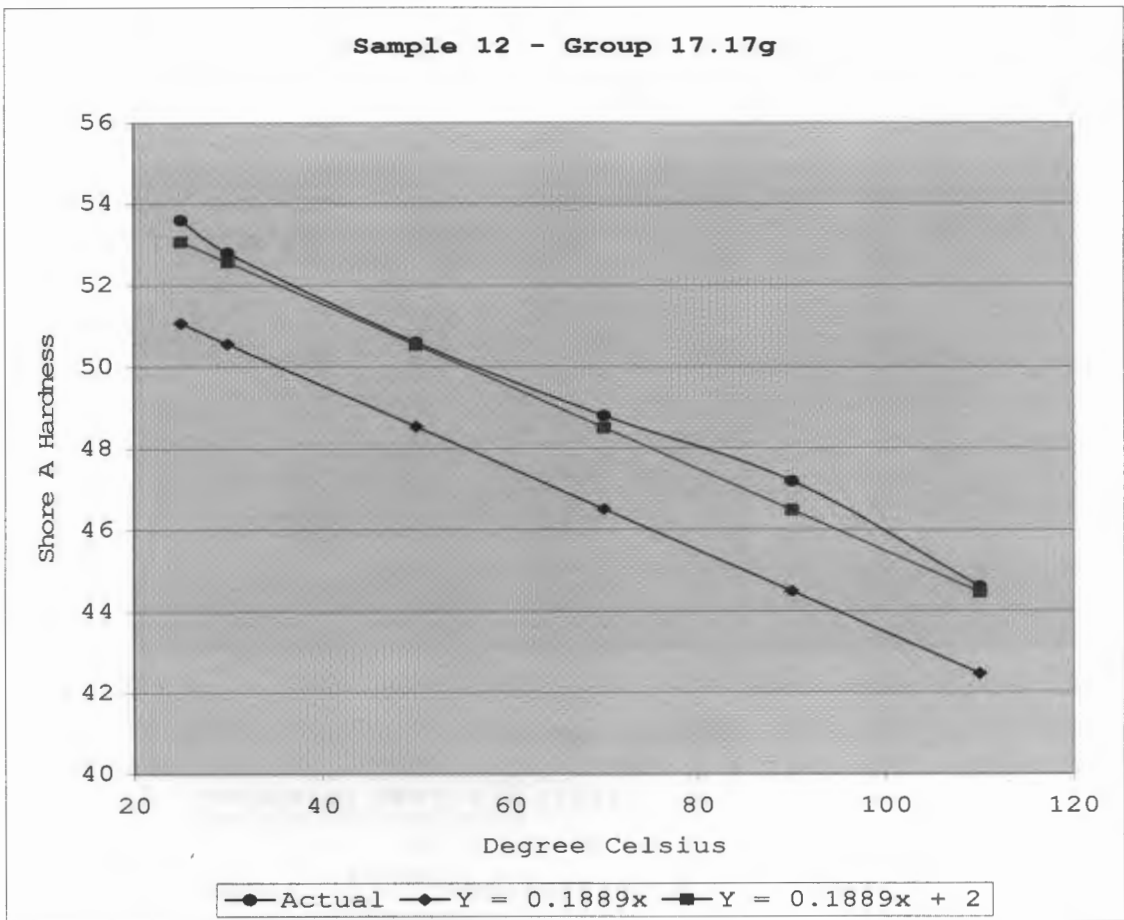

Figure 12 Sample 12 has the least surface area of weight group 17.17 g.

Sample 12 has the least uniform thickness combined with the smallest surface area yields the second largest percentage change in hardness for this group. Discounting the largest percentage change of sample 10, this slope follows the overall trend of smallest surface area having the greatest slope within a weight class.

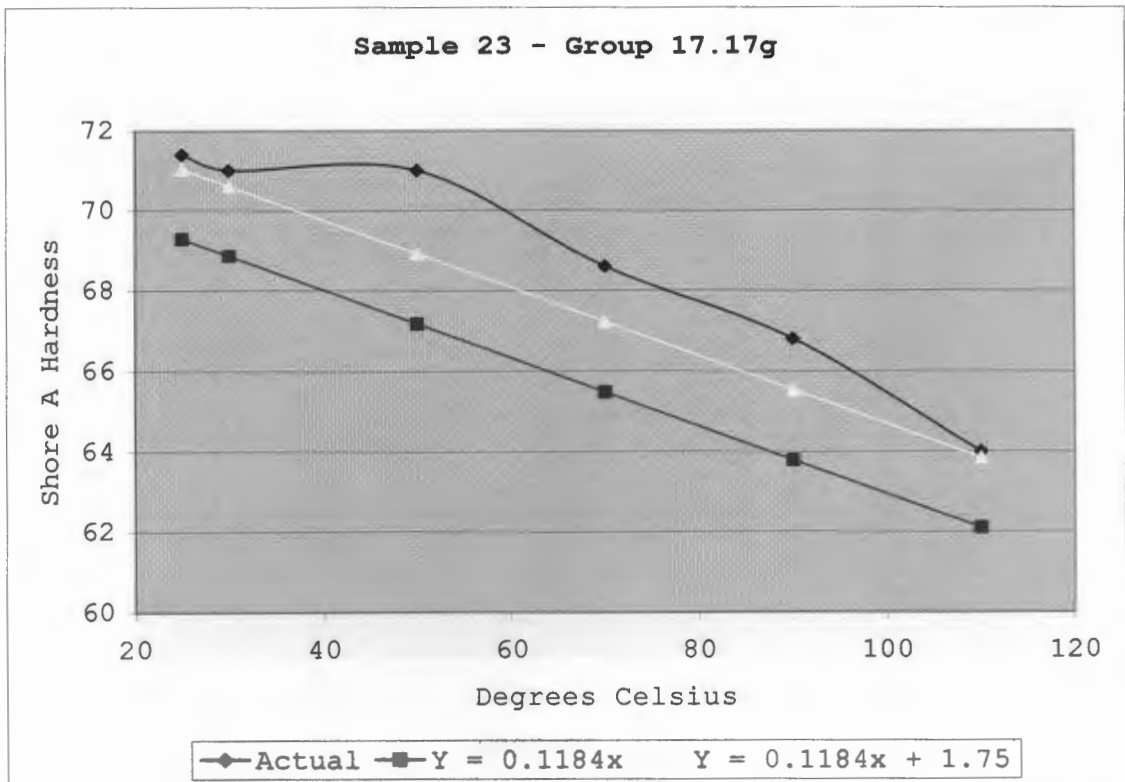

Figure 13 Sample 23 2nd smallest area but heaviest of weight group 17.17 g.

Sample 23 exhibits the shallowest slope but was the heaviest at 17.56 grams and had the least time of 64 seconds to complete the trials.

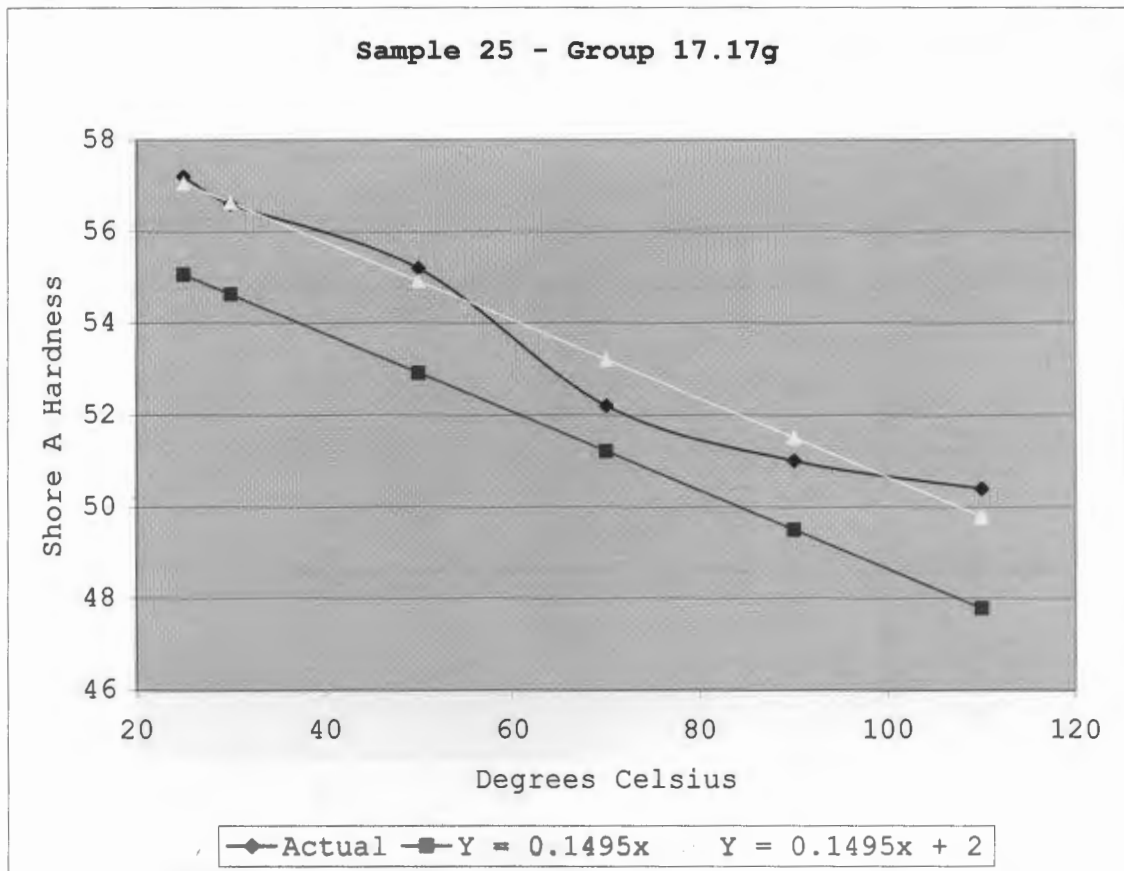

Figure 14 Sample 25 possesses the largest area and the 2nd longest time of weight group 17.17 g.

Removing sample 10, this would have the longest exposure time primarily due to the large surface area acting to cool off this piece requiring additional microwave energy. This process is exacerbated by the fact that this has the least weight of the 17.17 gram group.

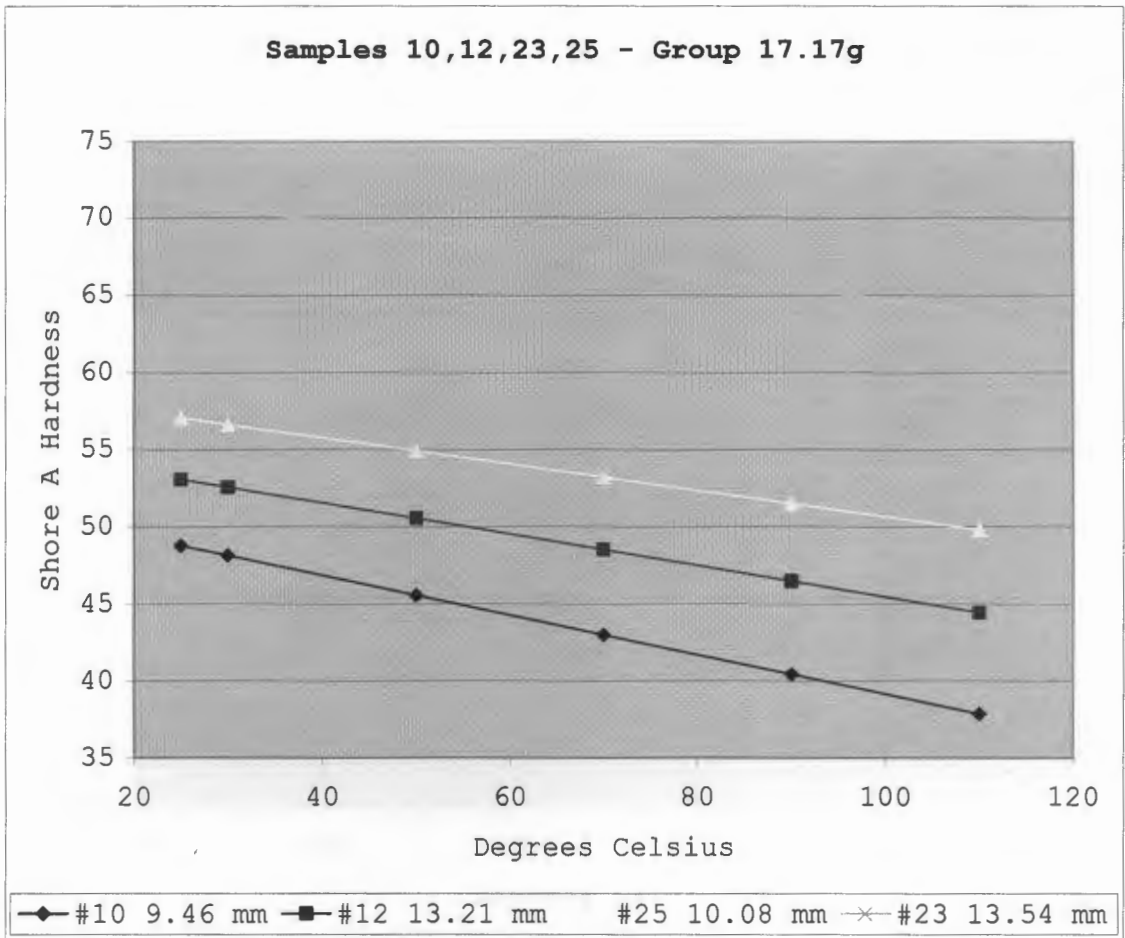

Figure 15 Hardness slope of average 17.17 gram samples.

Sample 23 displays higher hardness values due to variability in its composition. Although these samples have heterogeneous structures, as shown in Figure 15, they exhibit similar responses when exposed to microwave energy. This next heaviest group continues the saga of the lowering of exposure time to complete the trials to an average of 119 seconds.

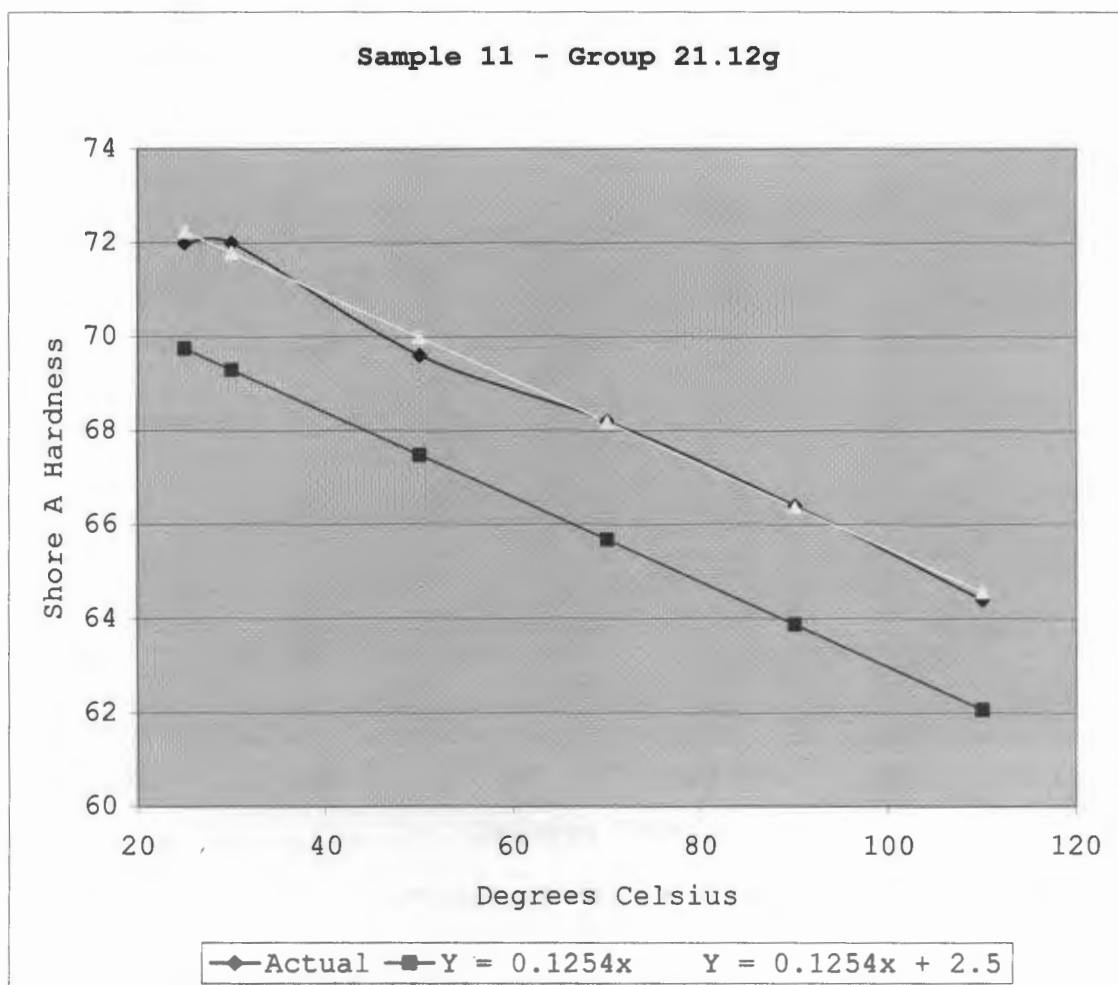

Figure 16 Sample 11 is heaviest, thickest, with the least surface area of weight group 21.12 g.

The properties that this sample possesses should lend it to having the steepest slope of the group. It does not have the steepest slope, that is reserved for sample 18 in Figure 18. However, sample 11 used the least amount of time to complete the trial at 80 seconds versus the average for the group at 104 s.

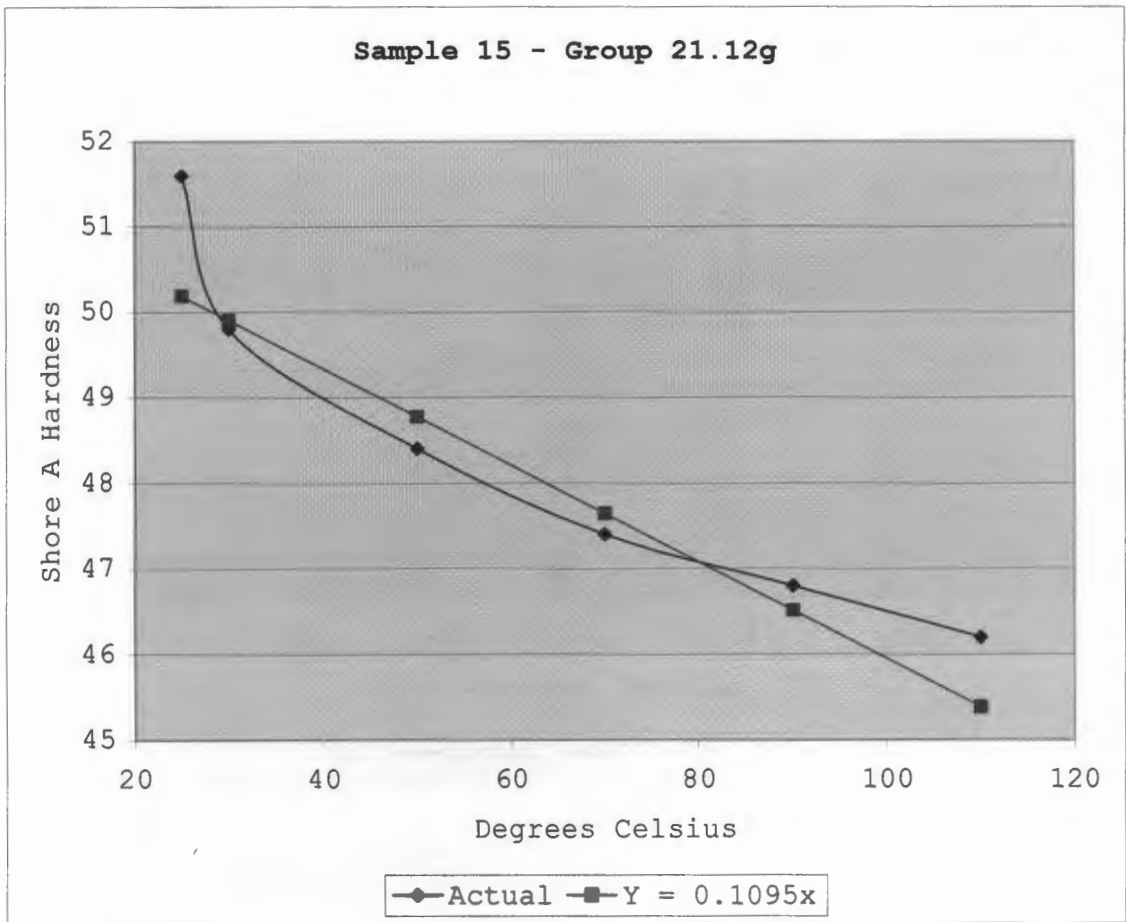

Figure 17 Sample 15 least weight and greatest exposure time for weight group 21.12 g.

Sample 15 reinforced the notion of least weight and minimal thickness required the most exposure time. The increased time actually reflects only a 10.47 % reduction in hardness versus other samples within the group yielding a higher percentage rate reduction.

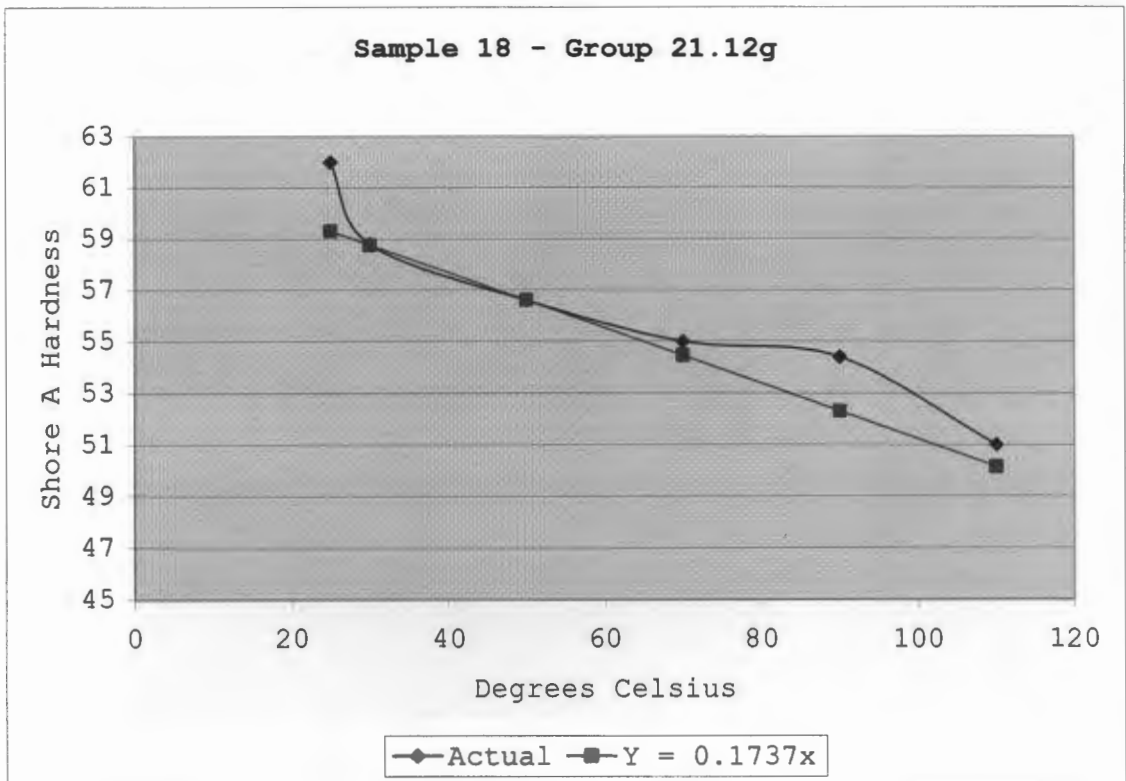

Figure 18 Sample 18 aggressive slope with greatest surface area of weight group 21.12 g.

Of all the specimens, sample 18 does not fit the trends that the majority of the test population followed. Upon closer examination of the subject, it seemed the surface was cracked and appeared to be older than the other samples. Cracked and aged rubber apparently increased the susceptibility of this sample to microwave energy reflected in the 17.74 % reduction in shore A values.

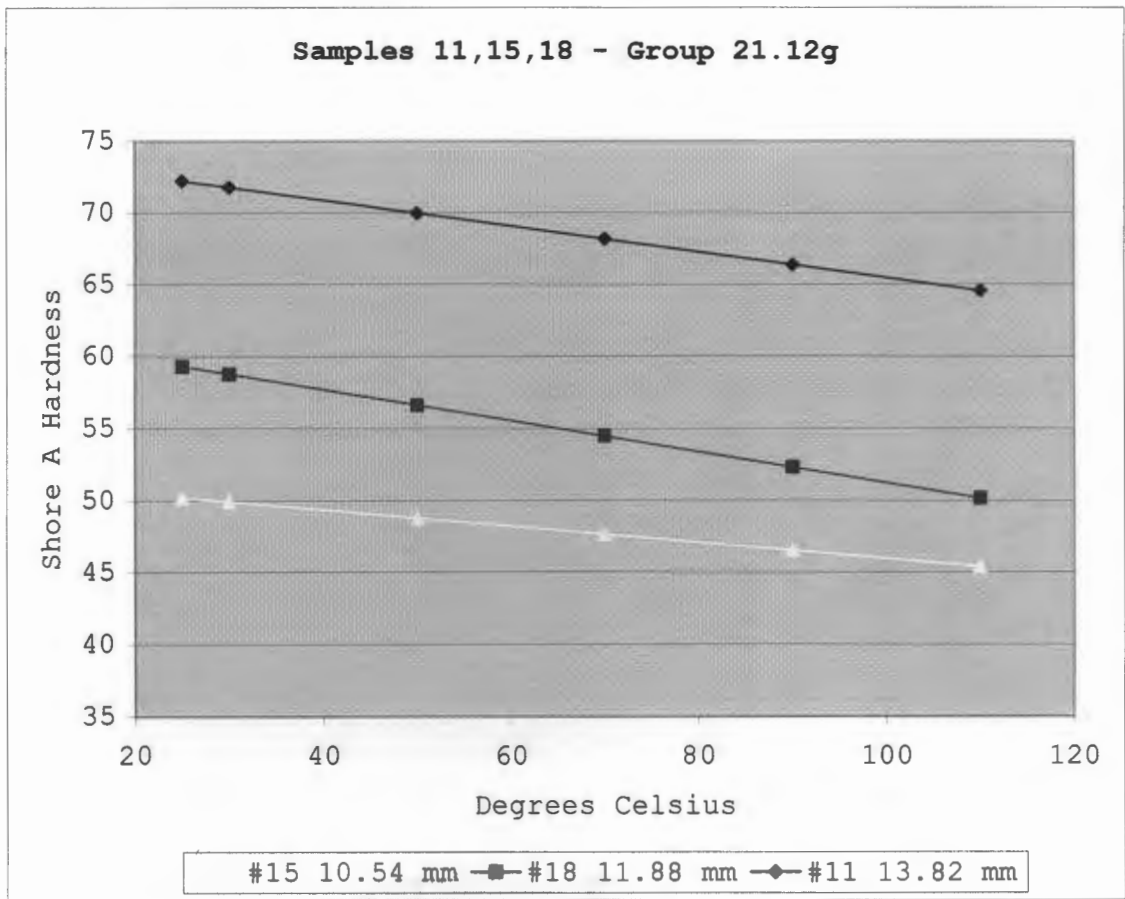

Figure 19 Hardness slope of average 21.12 gram samples.

As questionable as the results from sample 18 seem to be, all samples still track reasonably well together as shown in Figure 19. By removing sample 18, the other samples follow trends previously established. Nonetheless, this group averaged 104 seconds to complete the battery of tests.

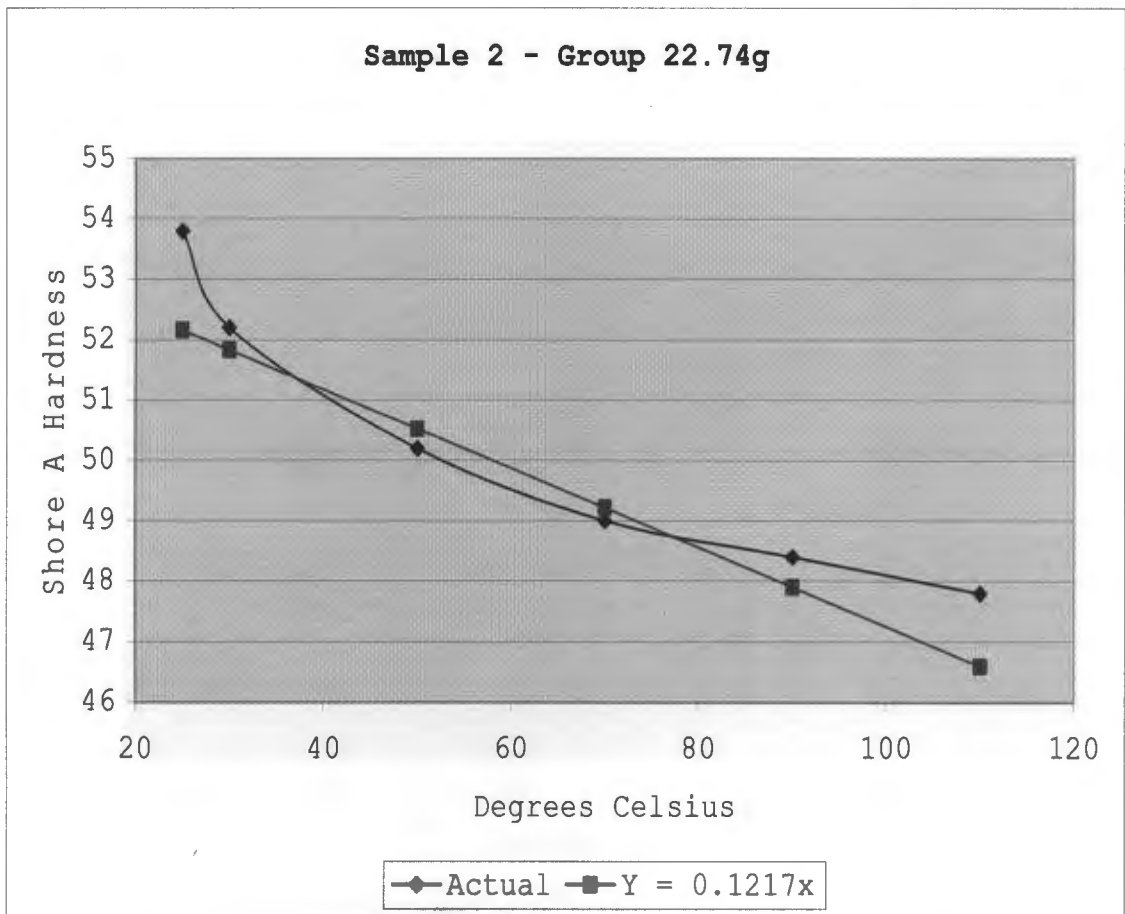

Figure 20 Sample 2 largest surface area with least average depth of weight group 22.74 g.

Sample 2 adhered to the rule of the largest surface area specimen requiring the most energy exposure to finish the trial for this 22.74 g weight group. This specimen needed 84 seconds of total exposure time.

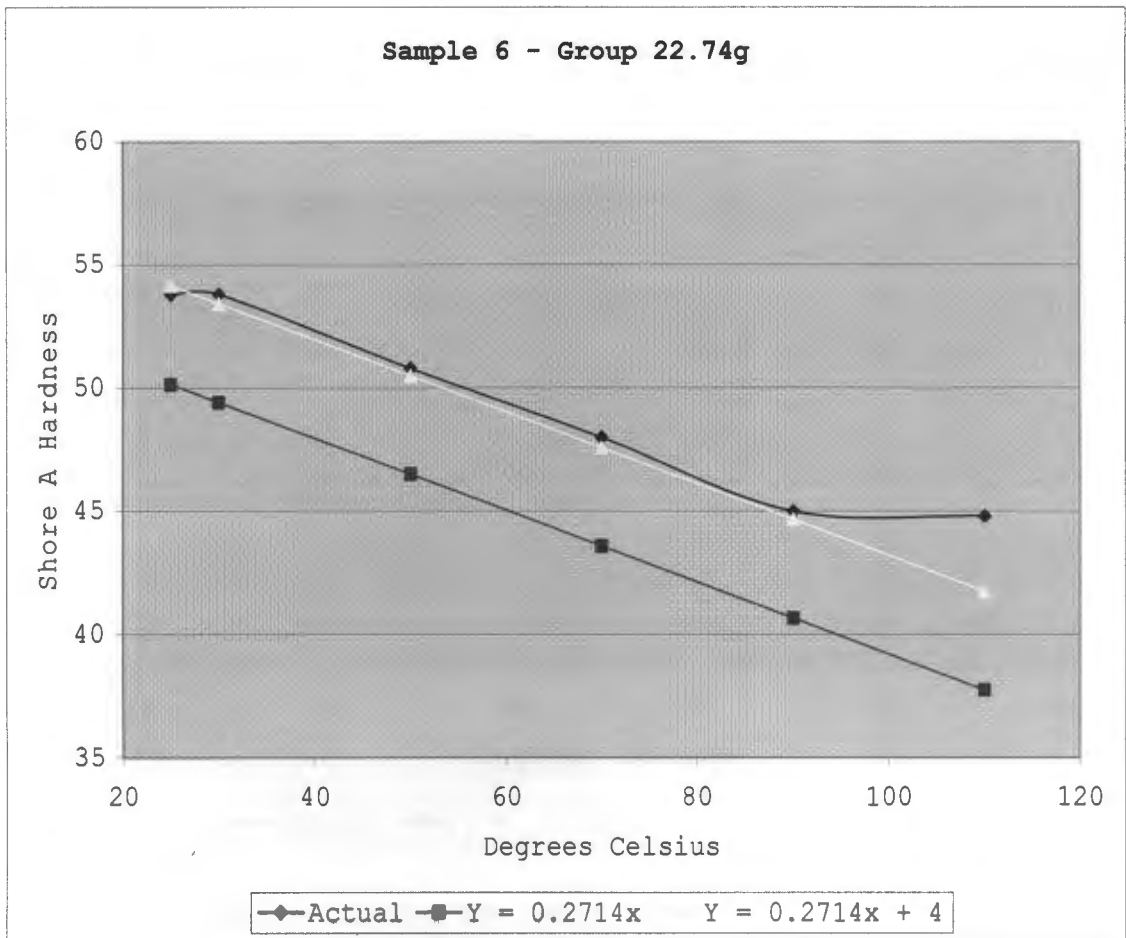

Figure 21 Sample 6 least weight and smallest area of weight group 22.74 g.

Figure 21 shows that sample 6 has the steepest slope of this group. This result is in line with the tendency of the smallest surface area focusing the most heat and creating the greatest amount of hardness change over the temperature range. Along with the steepest slope this part required the least exposure time at 64 seconds.

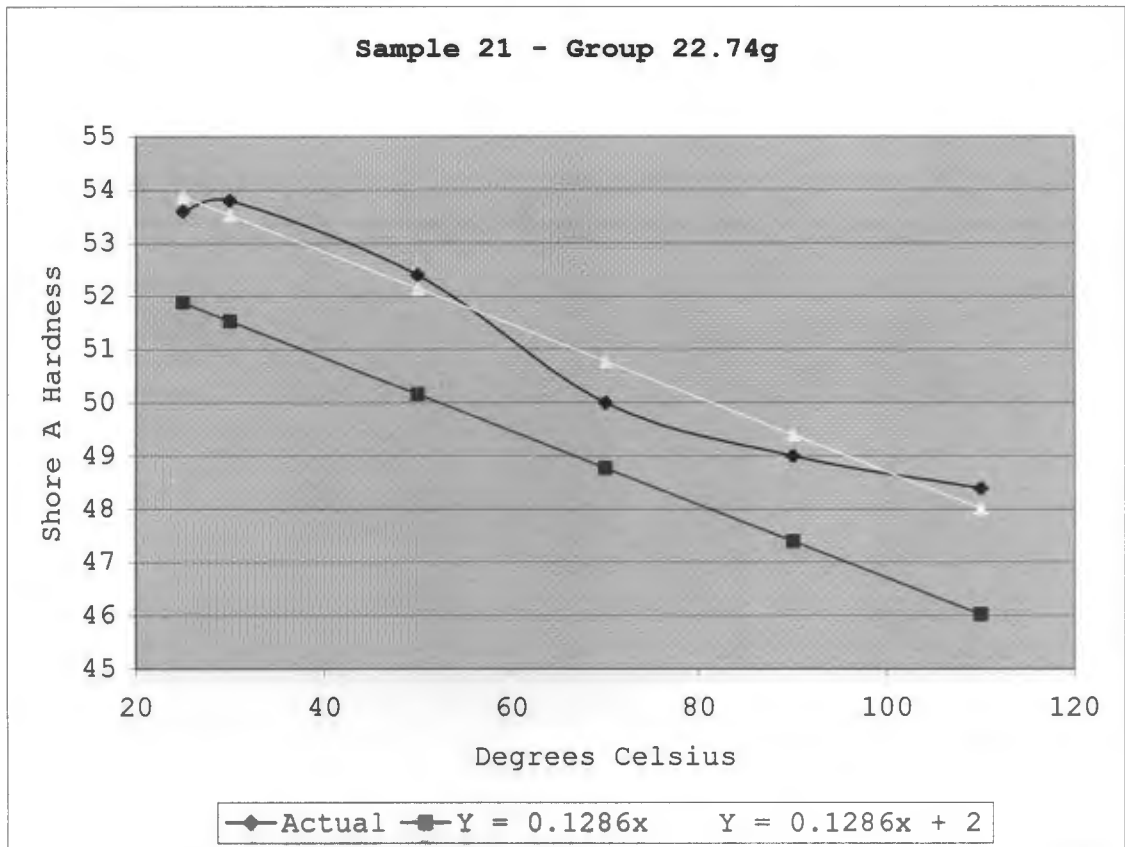

Figure 22 Sample 21 had the most mass and 2nd lowest surface area of weight group 22.74 g.

Sample 21 had the second lowest surface but possessed the highest mass of this group. It is interesting to note however that this specimen exhibited the least hardness percent change. Surface area trend of requiring more heat time, at 79 seconds, was adhered to for this sample.

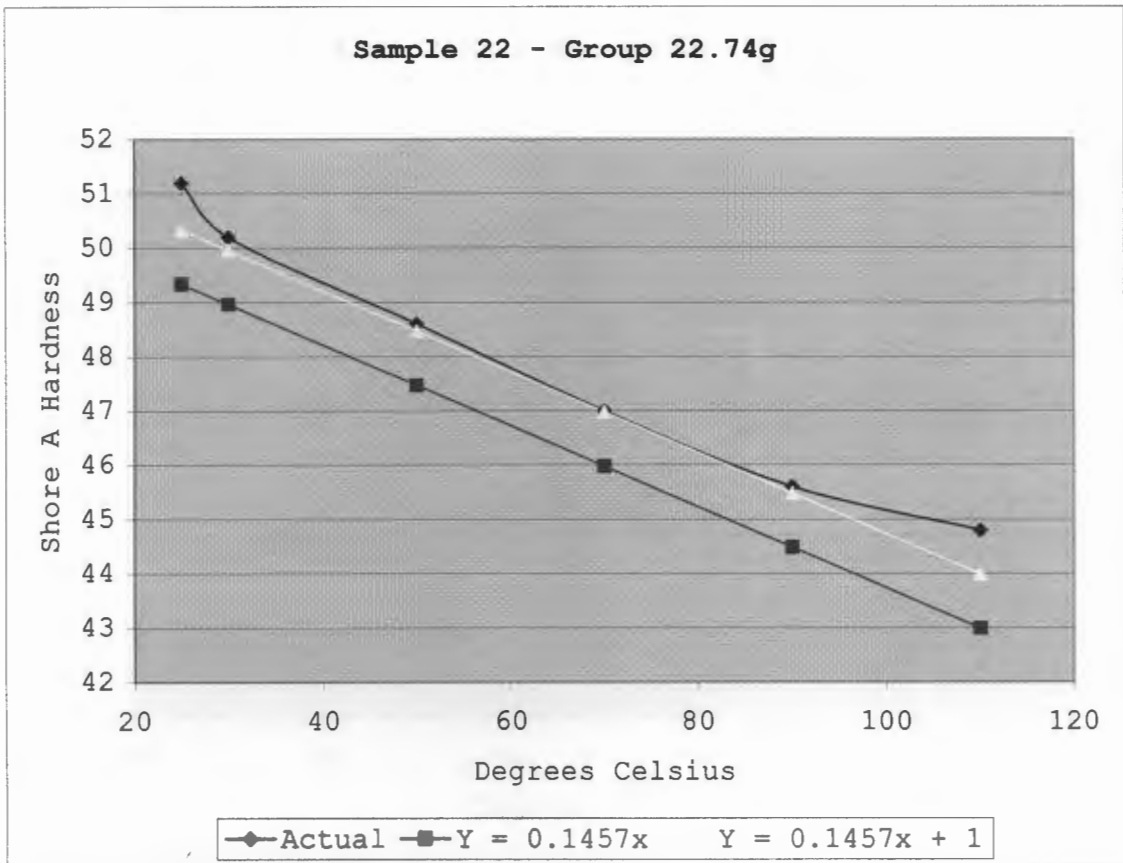

Figure 23 Sample 22 had 2nd least mass and 2nd largest surface area of weight group 22.74 g.

Being close to the largest surface area and light like this sample 22 shown in Figure 23 is, one would expect a hardness percentage change to be the second lowest of the group however, the opposite is the case. This piece is the second highest for the group and used the most heat time. Material variability obviously played a role with these test results.

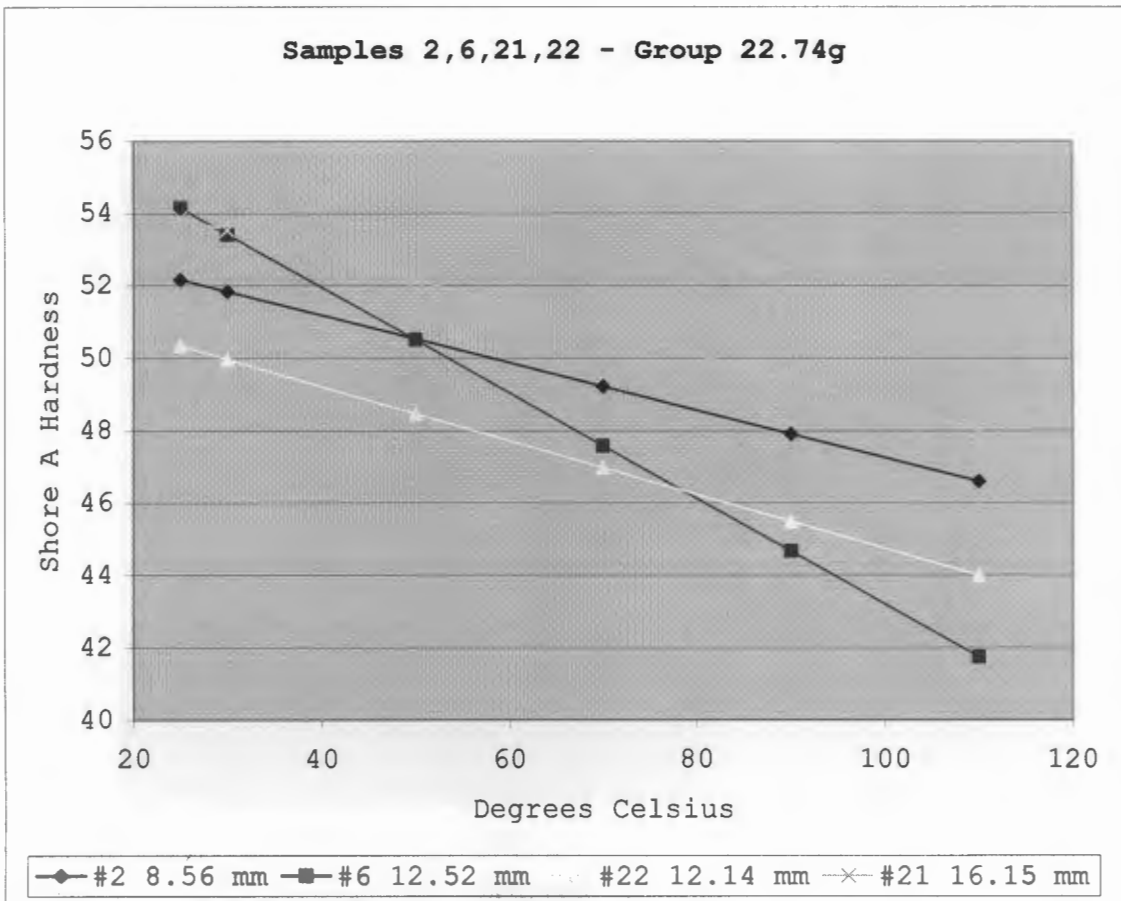

Figure 24 Hardness slopes of average 22.74 gram samples.

Remove sample 6 intersecting slope line from Figure 24 and the other calculated slopes show strong correlation to one another. As a group, overall time of 85.75 seconds to complete the tests followed the trend of increased mass equaled less exposure time versus the other groups with less weight.

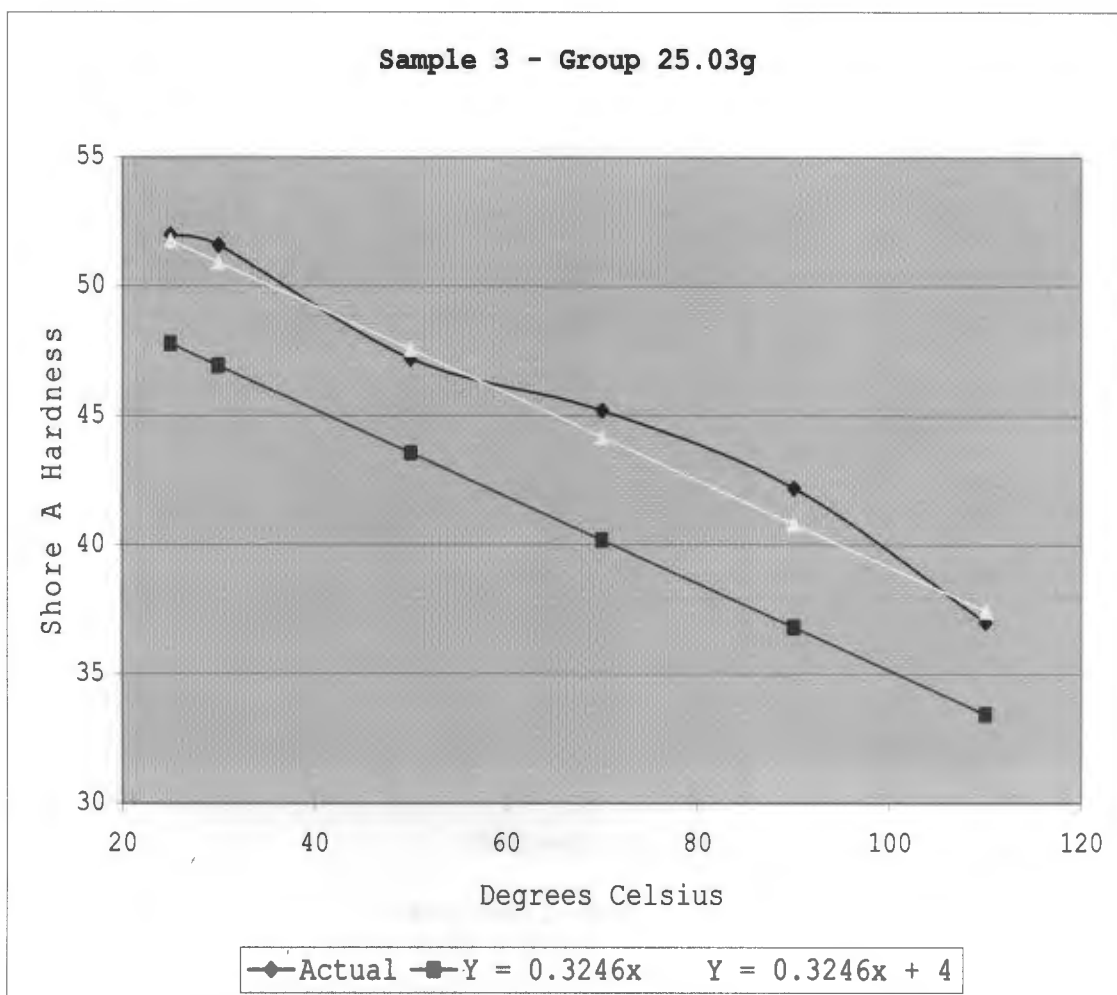

Figure 25 Sample 3 has greatest mass and almost smallest area of weight group 25.03 g.

Sample 3 with the most weight and nearly the smallest surface area produced the greatest slope for this weight class. Given that data, it still followed the surface area rule of having the second least exposure time.

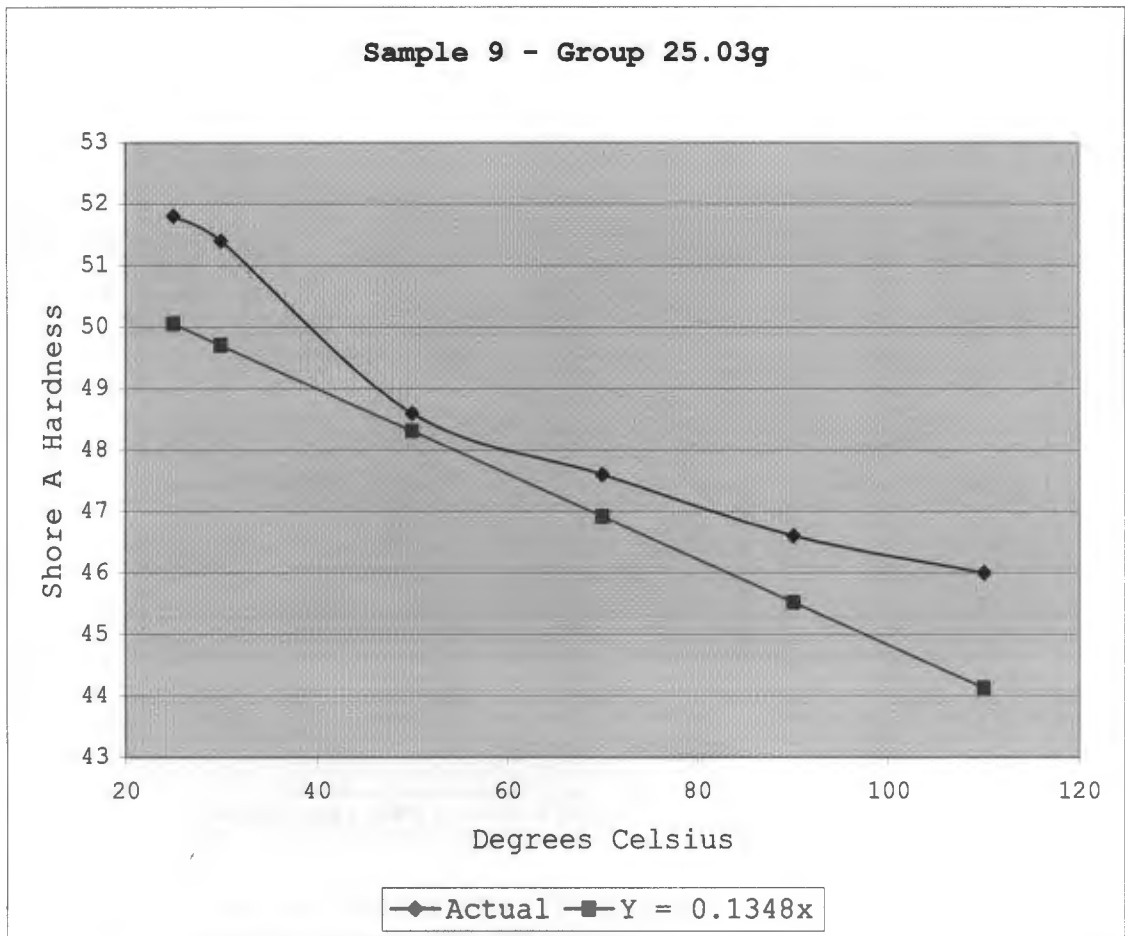

Figure 26 Sample 9 has most surface area for weight group 25.03 g.

The large surface area is apparent by the actual values curving up in Figure 26 which indicated a convective heat loss from the surface. Further, this sample supports the theme of most heat time needed and least amount of change to hardness values for this group.

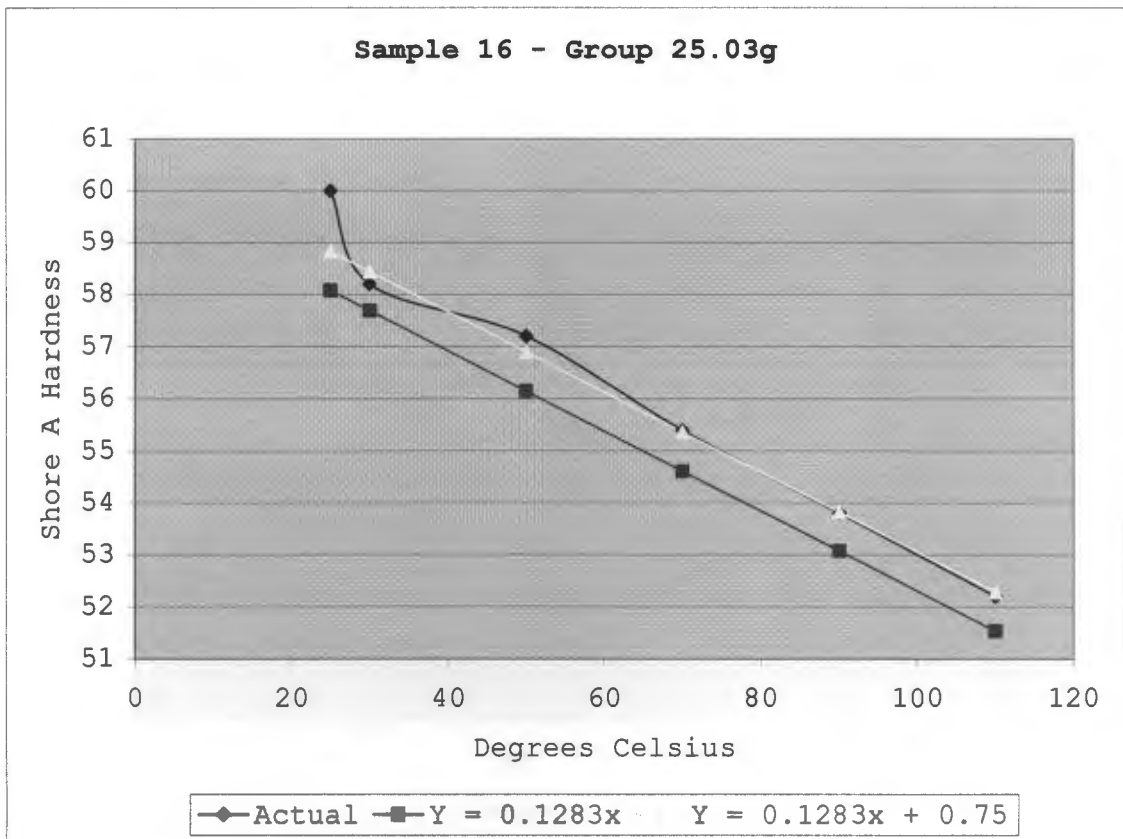

Figure 27 Sample 16 has the 2nd highest surface area of weight group 25.03 g.

This sample 16 in Figure 27 had a slightly larger than expected percent hardness change. This difference can be dismissed due to the sample having the second highest weight in the group. Sample 16 possessed the second largest surface area also required the second longest heat time for this group.

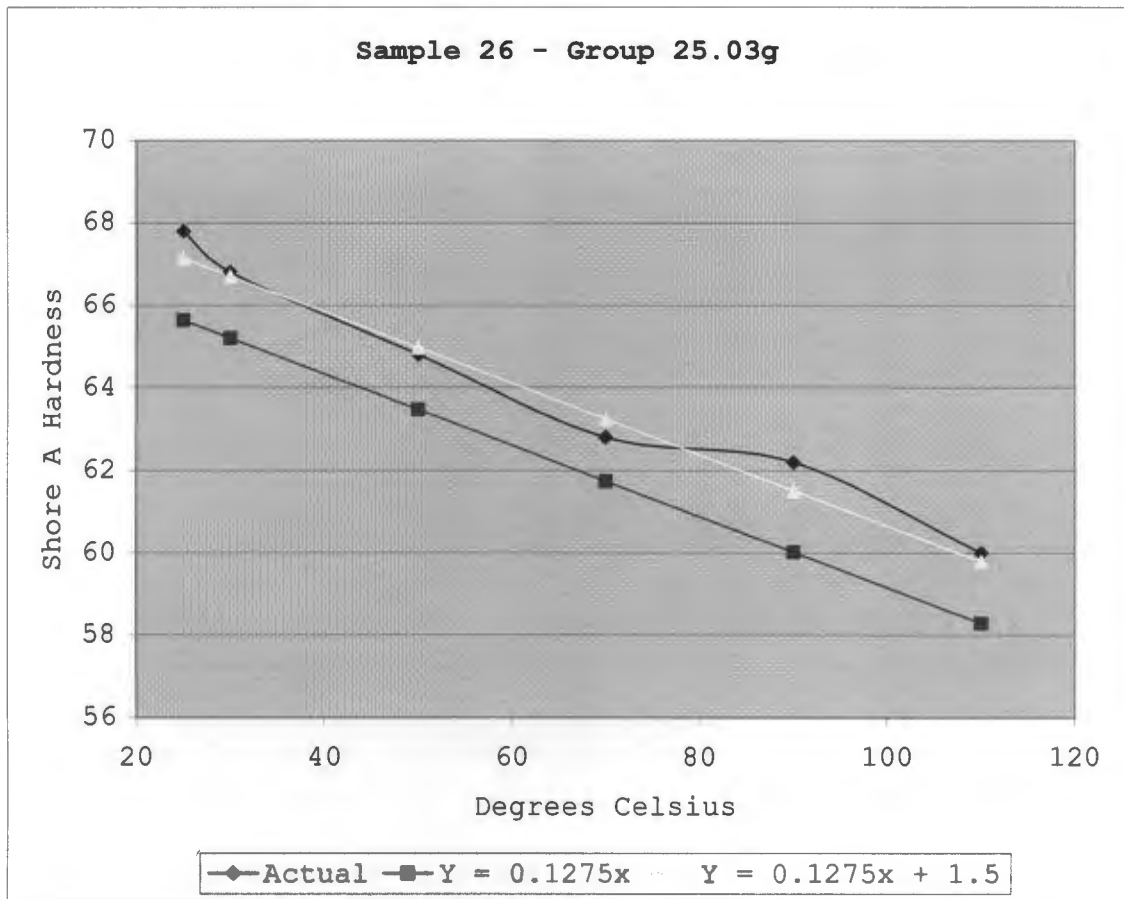

Figure 28 Sample 26 has the smallest surface area and the least mass of weight group 25.03 g.

Sample 26 shown in Figure 28 had the second worst hardness percent change of the group but required the least heat time owing to its small surface area. The small hardness change is most likely due to the low mass of this sample.

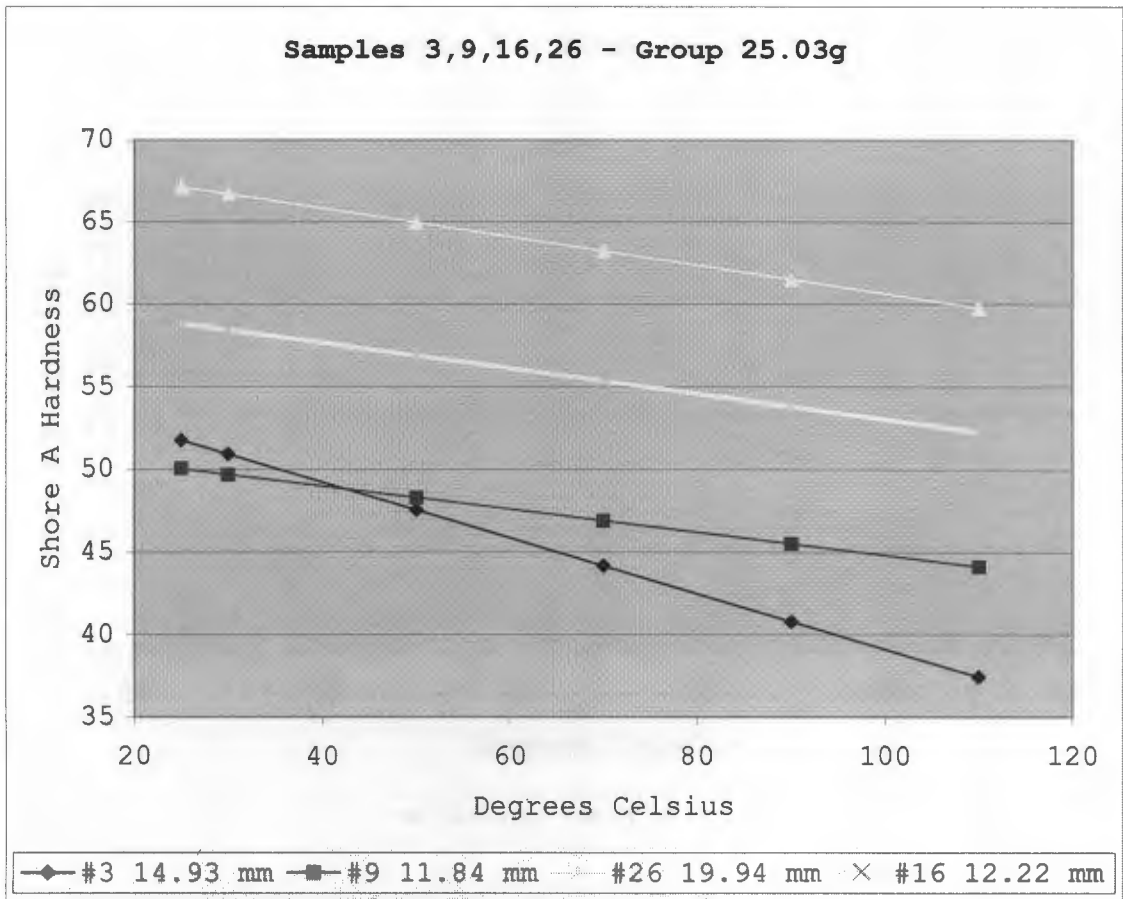

Figure 29 Hardness slopes of average 25.03 gram samples.

Group 25.03 g in Figure 29 shows the hardness changes of samples 3, 9, 16, and 26. All samples follow expected outcomes based on their physical properties and the trends revealed due to volumetric heating. As a group the average heat time decreased to 74 seconds.

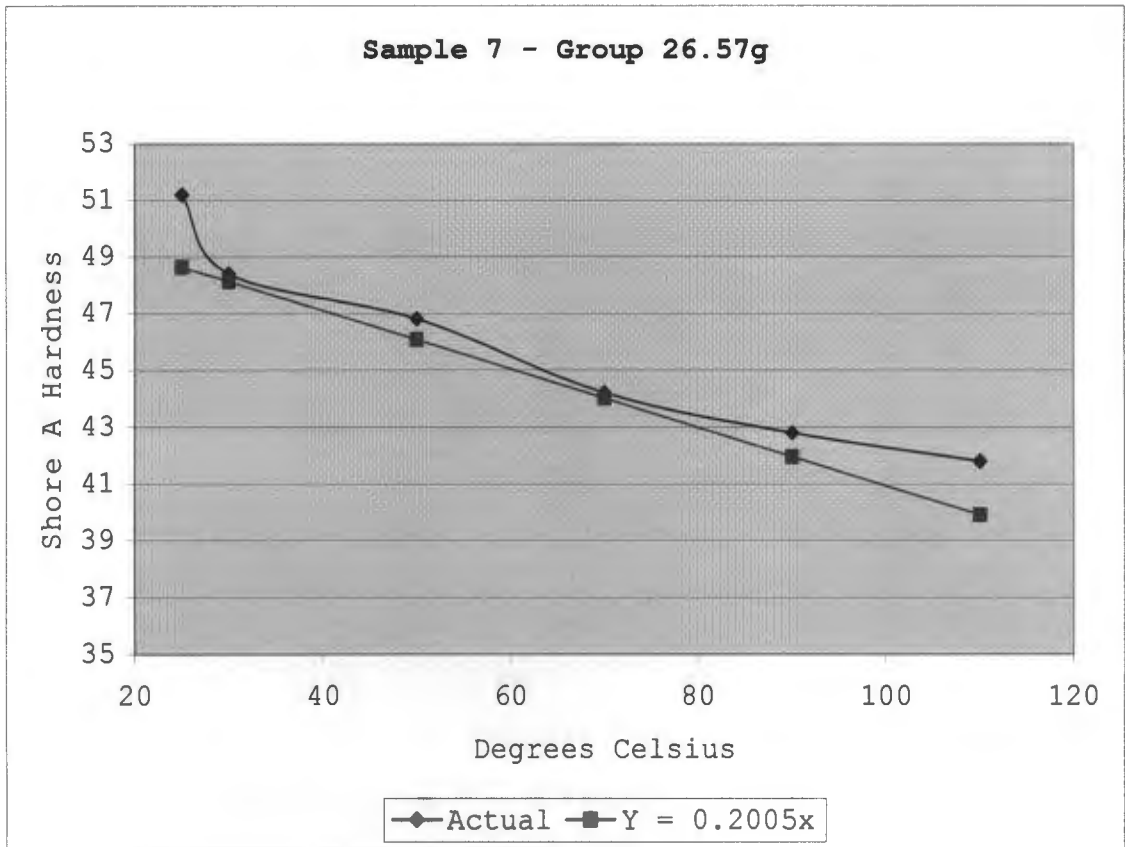

Figure 30 Sample 7 has least surface area and most weight of weight group 26.57 g.

Sample 7 in Figure 30 depicts the hardness change response that one would expect from a sample with the most weight and the least surface area, namely this sample has the largest percentage change for the group. If this sample followed the tendencies witnessed thus far, this sample should also have the lowest heat time. Inescapably, this sample has the most heat time.

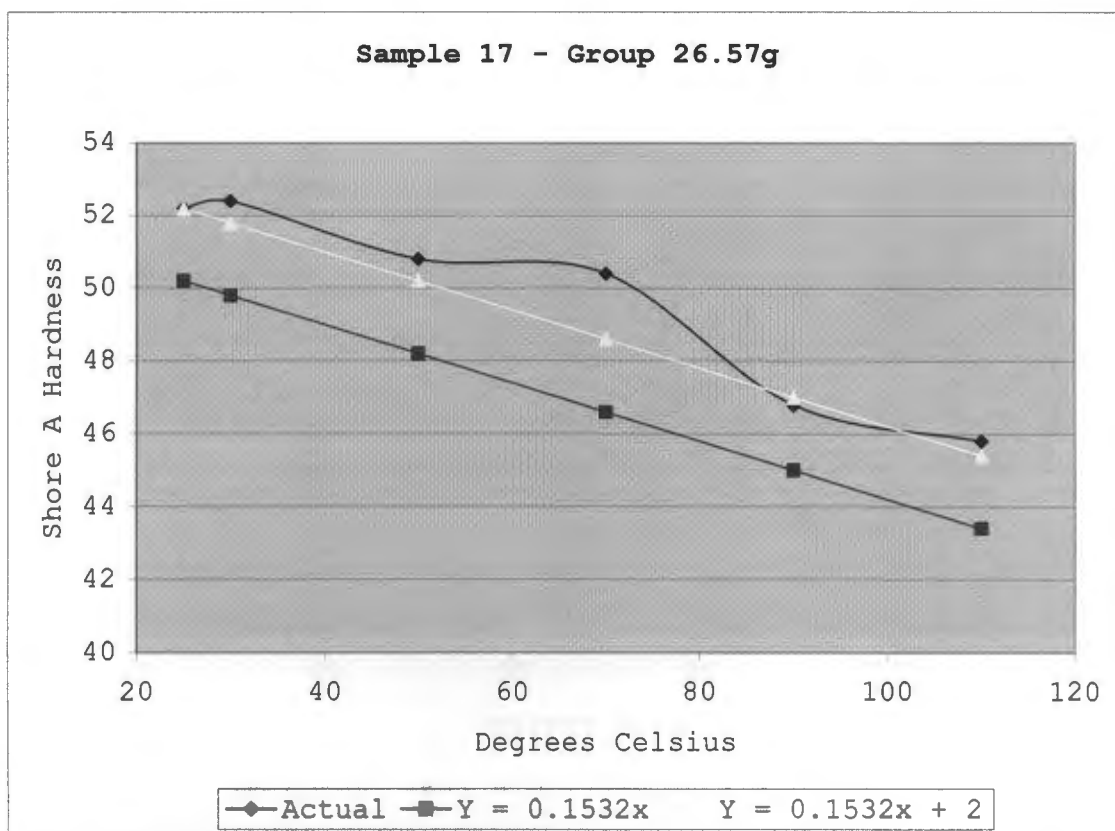

Figure 31 Sample 17 has the greatest surface area and 2nd highest weight of weight group 26.57 g.

Given the largest surface area of the group, sample 17 in Figure 31 shows the least hardness change over the temperature span. This sample has the least recorded heat time for the group when the longest period is expected due to its large surface area. The mass of the sample most likely contributed to short exposure times that were recorded.

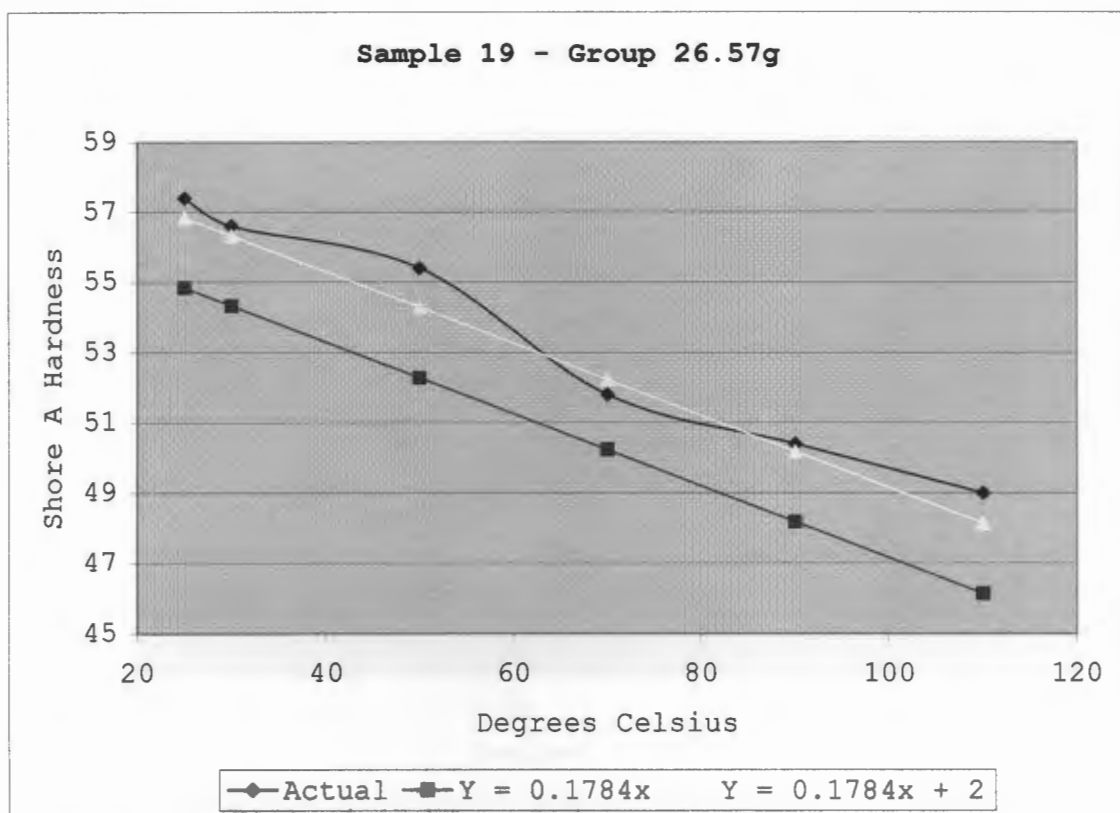

Figure 32 Sample 19 has almost the smallest surface area and least weight of weight group 26.57 g.

Sample 19 in Figure 32 reveals its middle of the group hardness change matching its physically median surface area. Sample also displayed midpoint energy exposure time.

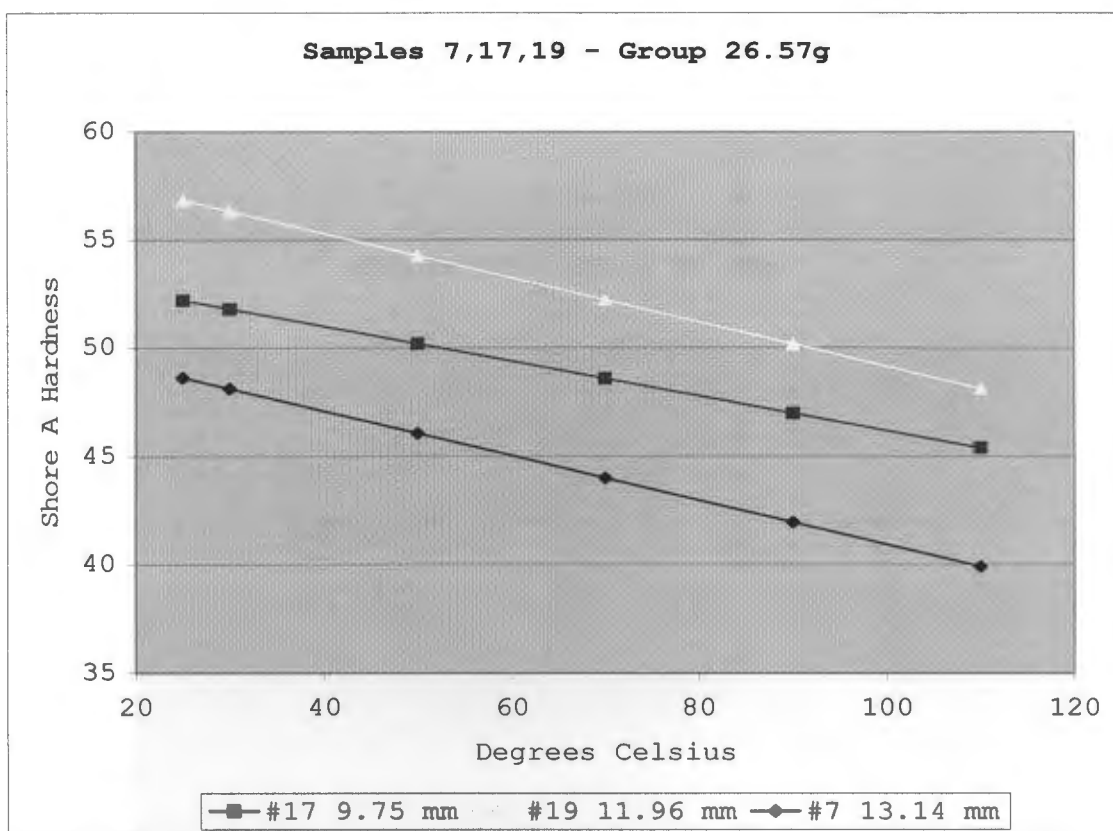

Figure 33 Hardness slope of average 26.57 gram samples.

The individual samples 7, 17, and 19 of Group 26.57 g in Figure 33, follow the established trends of hardness change. However, as a group the elapsed heat exposure times are flipped from what has been experienced to this point. To further emphasize this point, given this weight class, an average heat time in the range of 67.3 to 74 seconds was expected. The actual average for this group was 109.3 seconds. This can be attributed to sample 7 and

19 extremely higher than normal times which will be considered an anomaly for this data set.

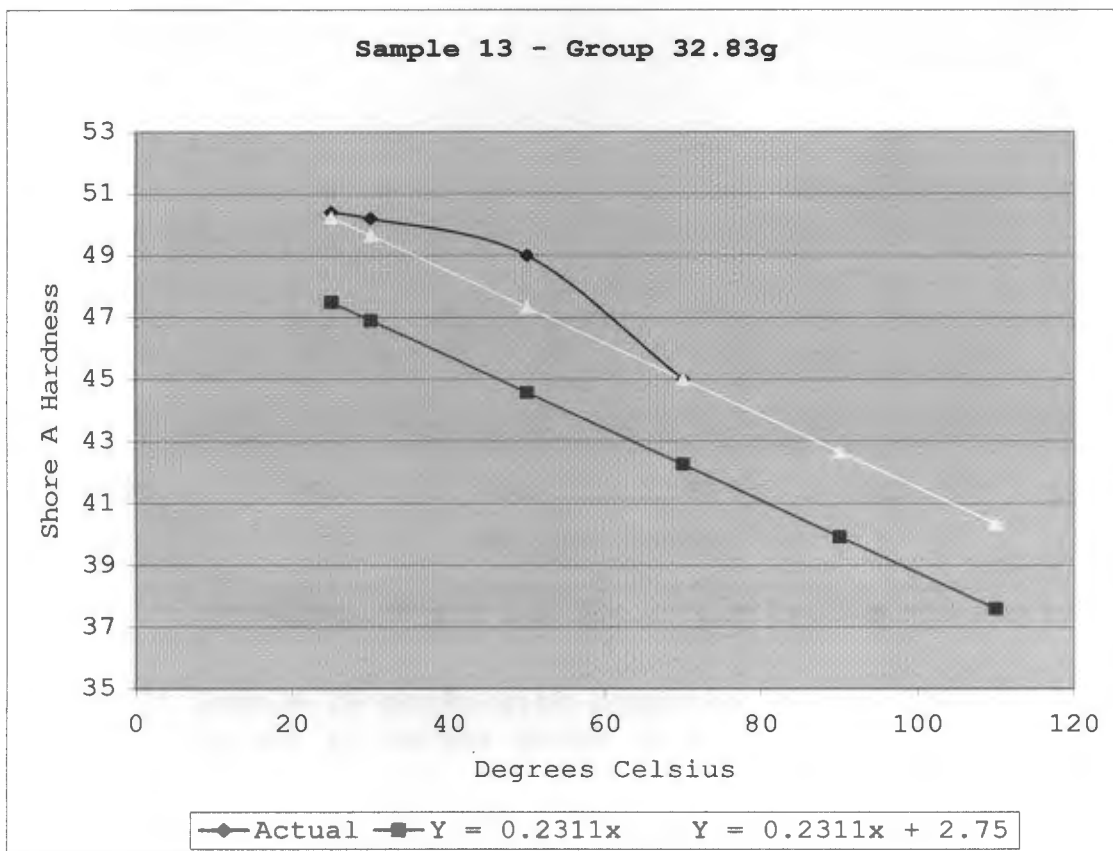

Figure 34 Sample 13 with calculated 90 and 110 °C values in weight group 32.83 g.

Figure 34 shows that sample 13 DNF this set of tests primarily due to the piece forming a heat induced bubble. Sample 13 was the thickest with the smallest surface area and had the largest calculated hardness change for the group.

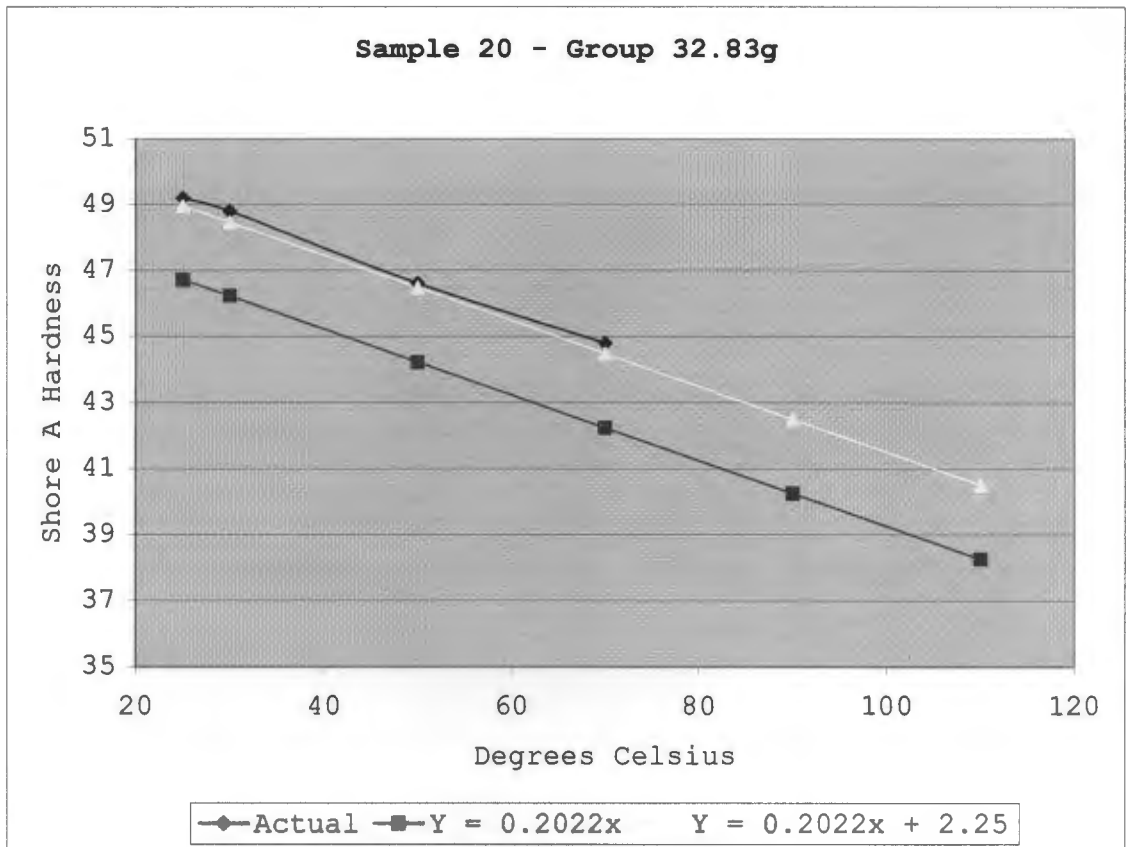

Figure 35 Sample 20 shown with computed 90 and 110 °C values in weight group 32.83 g.

Sample 20 as shown in Figure 35 is by physical characteristics is in the middle for this weight class. As such, it exhibits the second highest decrease in hardness change after sample 13 in Figure 34. However, both samples recorded small exposure times due to them not finishing these trials.

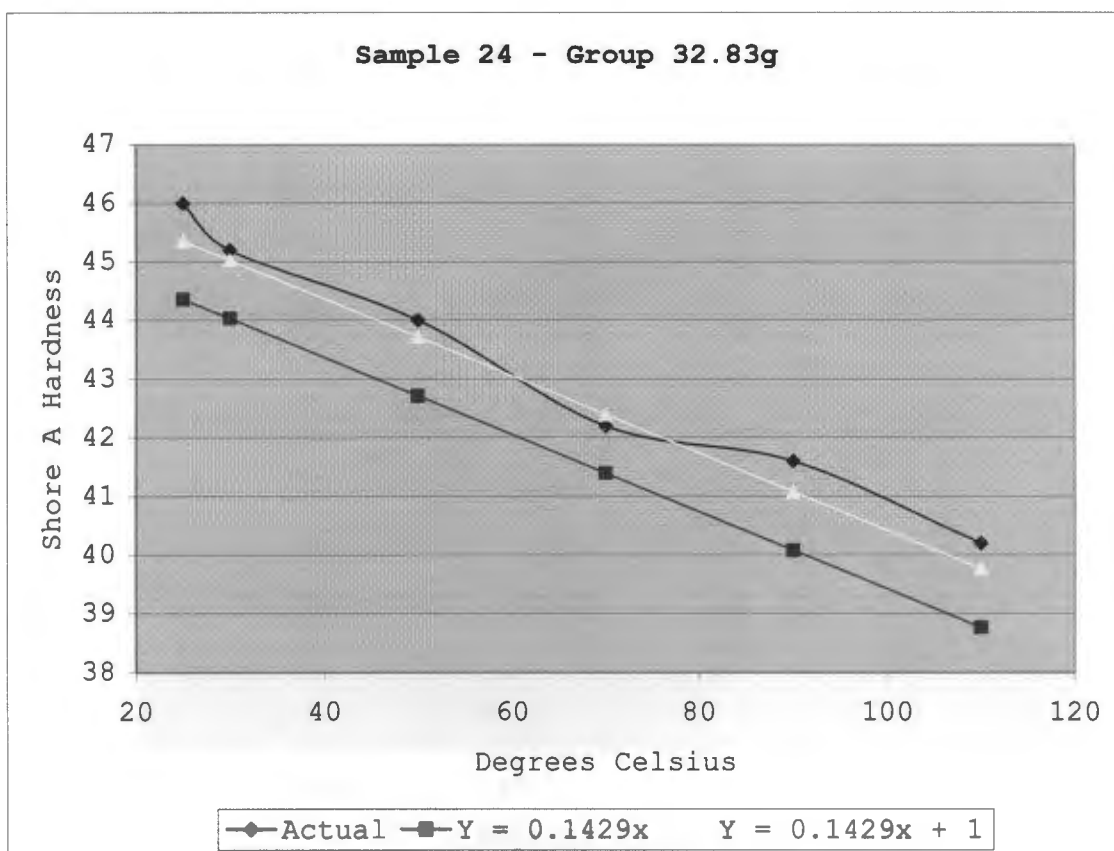

Figure 36 Sample 24 with largest surface area and mass for weight group 32.83 g.

For this weight class, sample 24 in Figure 36, was the only specimen that finished the full battery of trials. Sample 24 had the most mass and the greatest surface area which allowed it to expel heat in a more efficient manner. This piece had the least hardness percent change for the group and had the highest exposure time, in line with expectations.

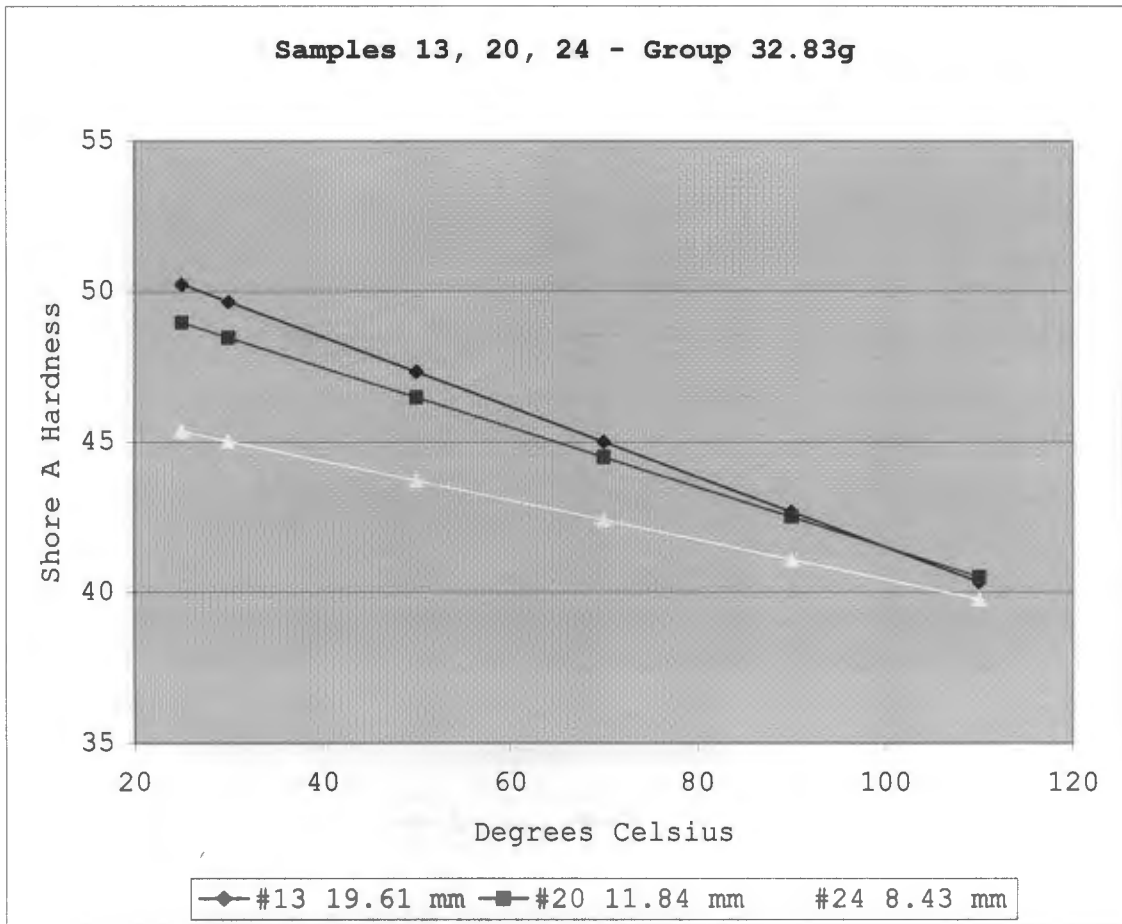

Figure 37 Hardness slope of average 32.83 gram samples.

Group 32.83g in Figure 37 is one of two groups that have members with weights in excess of 30 grams. This group follows the trend of less exposure time as weight increased, however, due to two members not completing the full test, the average exposure time is marginally valid at best. The group recorded an average time of 67.3 seconds.

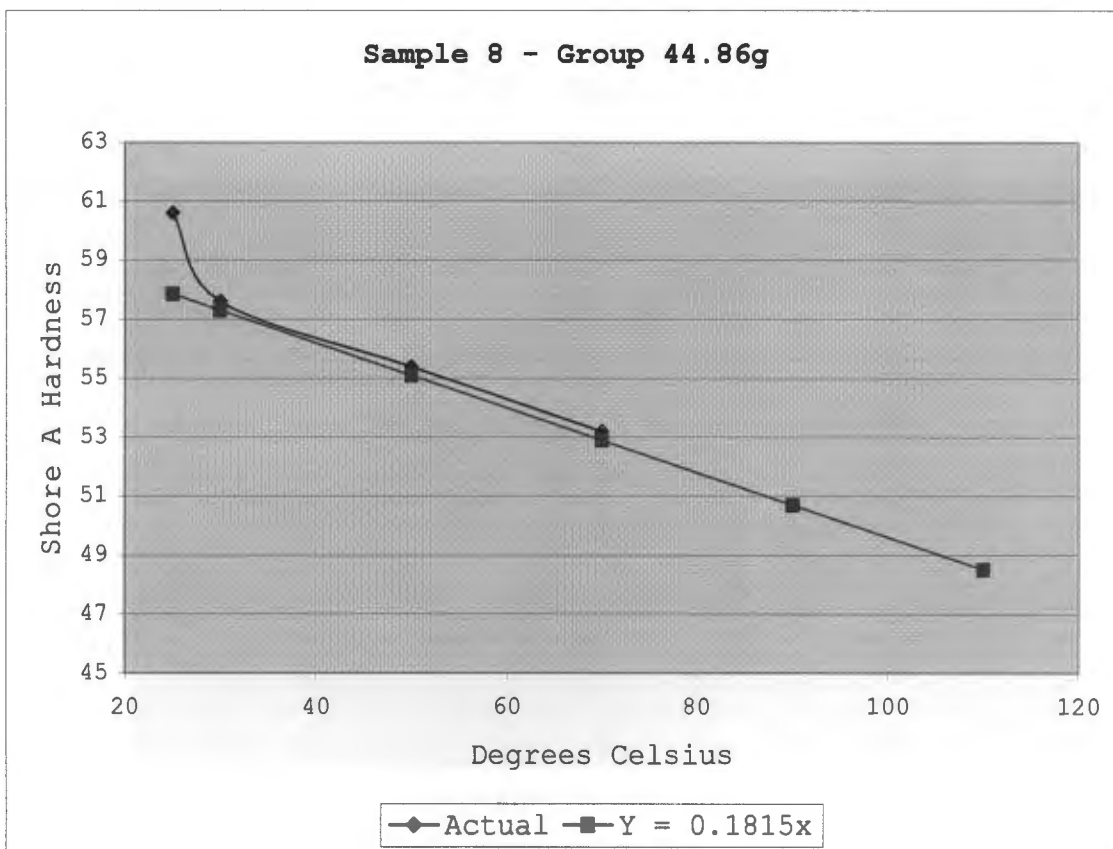

Figure 38 Sample 8 with calculated 90 and 110 °C values for weight group 44.86 g.

Sample 8 in Figure 38 is the third specimen with weight exceeding 30 grams to not finish these tests. The calculated values indicated that this sample would have adhered to the trend of having the largest hardness percentage change over the temperature range if it had finished the trials.

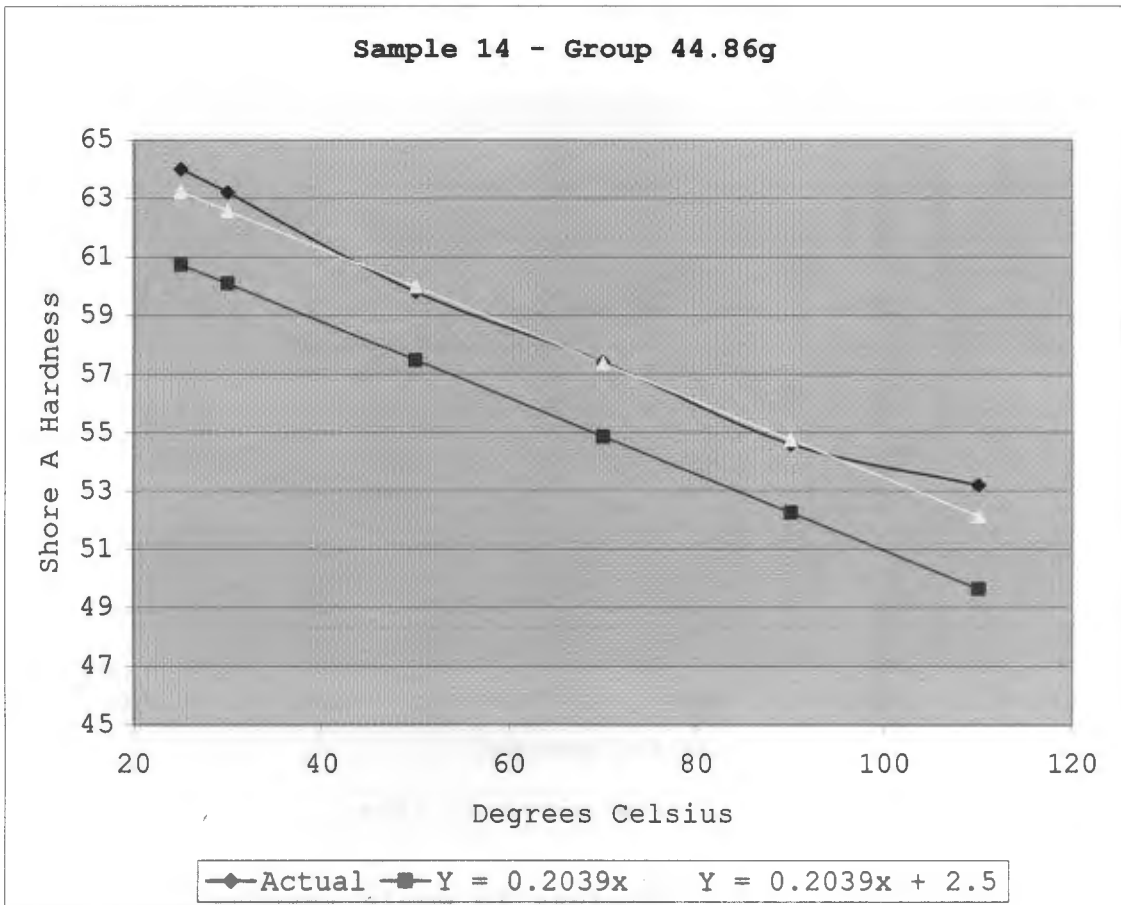

Figure 39 Sample 14 has largest surface area and least weight of weight group 44.86 g.

Sample 14 in Figure 39 with the most surface area had minimal hardness percentage drop over the temperature range. This sample followed the establish trend of using the most exposure time. However, the amount of time this sample used can not be directly compared to sample 8 in Figure 38 since sample 8 DNF.

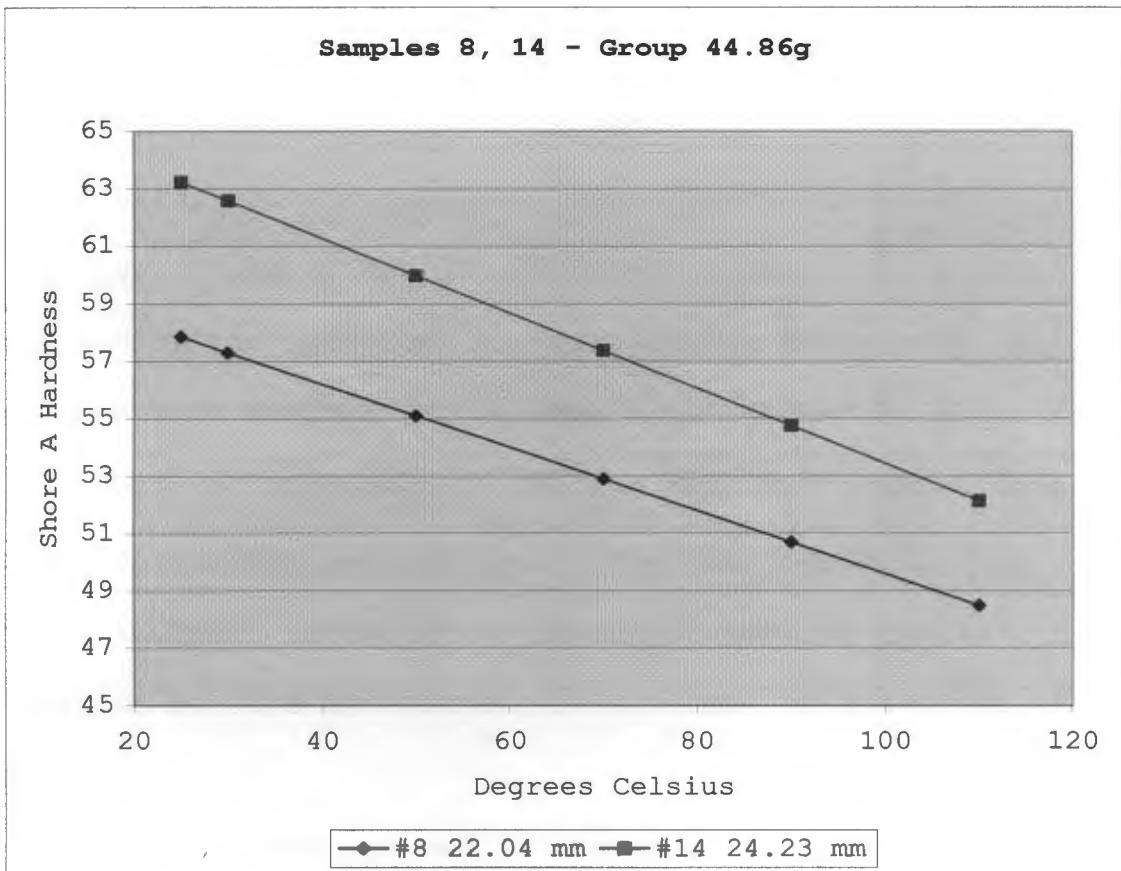

Figure 40 Hardness slope of average 44.86 gram samples.

Group 44.86g in Figure 40 is the heaviest and last group that was tallied. Like group 32.83g in Figure 37, this pair of specimens had one of its member fail to complete the tests. A heat step period of just four seconds was used for both groups, clearly this amount may have been too much for these samples since only two of the five members finished all hardness readings. This group averaged 66 seconds although sample 8 DNF.

Results from Phase Two Metal Containing Samples

This phase used just four samples to determine how scrap tires containing metal react during microwave heating. Three of the four samples produced sparking on one end of the spectrum and fire on the other end. All samples were weighed and surface areas judged to correlate with observed phenomenon. The two smallest samples were sourced from the same TDF pile shown in Figure 3. The other two much larger pieces were provided by Dennis Froelich at Tire Environmental Services, of Muscatine, Iowa.

Samples that ignited in flames were quickly extinguished by removing the microwave energy source. These pieces would smolder for a few seconds then cool to the touch within minutes.

Significant fire events only involved the two lightest pieces of the group. Suggesting a low mass part with wire within its structure concentrates the energy around the wire creating large heat induced pockets along the wire to rubber boundary layer. When this layer is exposed to air, a flame is emitted.

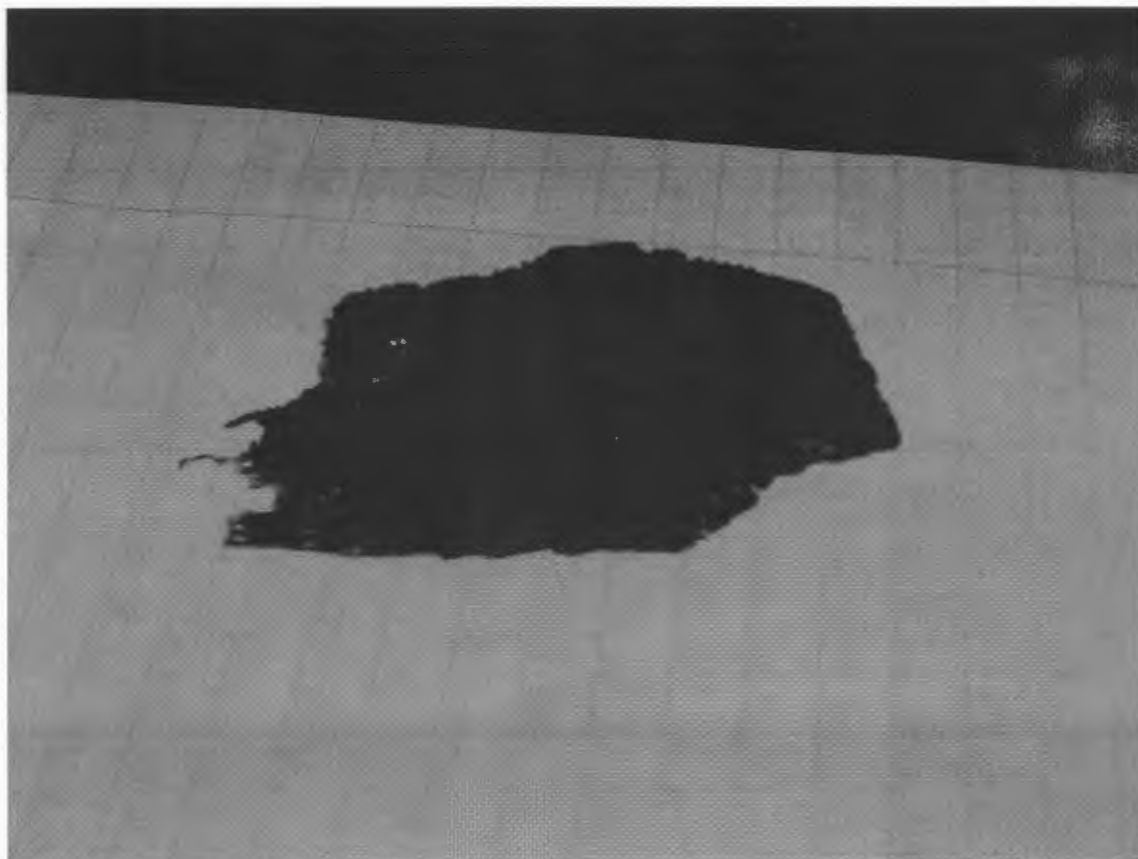

Figure 41 Photo of wire sample 1 weighed 11.02 grams exhibited the most flame of phase two samples.

Wire sample 1 in Figure 41 emitted flame almost immediately with the commencement of microwave energy excitation. The exothermic reaction was stopped by removing the energy source.

This sample had thin gage belt wire in loose bundles that created focus points for the electrons to be reflected from wire to wire and wire to rubber. Rubber did not reflect this energy instead the energy was converted into

heat within the rubber. This conversion occurred so rapidly that rubber burst into flame. Once burned, the rubber left a layer of carbon black on its surface. This carbon black layer acted much like a wire in reflection and concentration of microwave energy to cause more burning on the part.

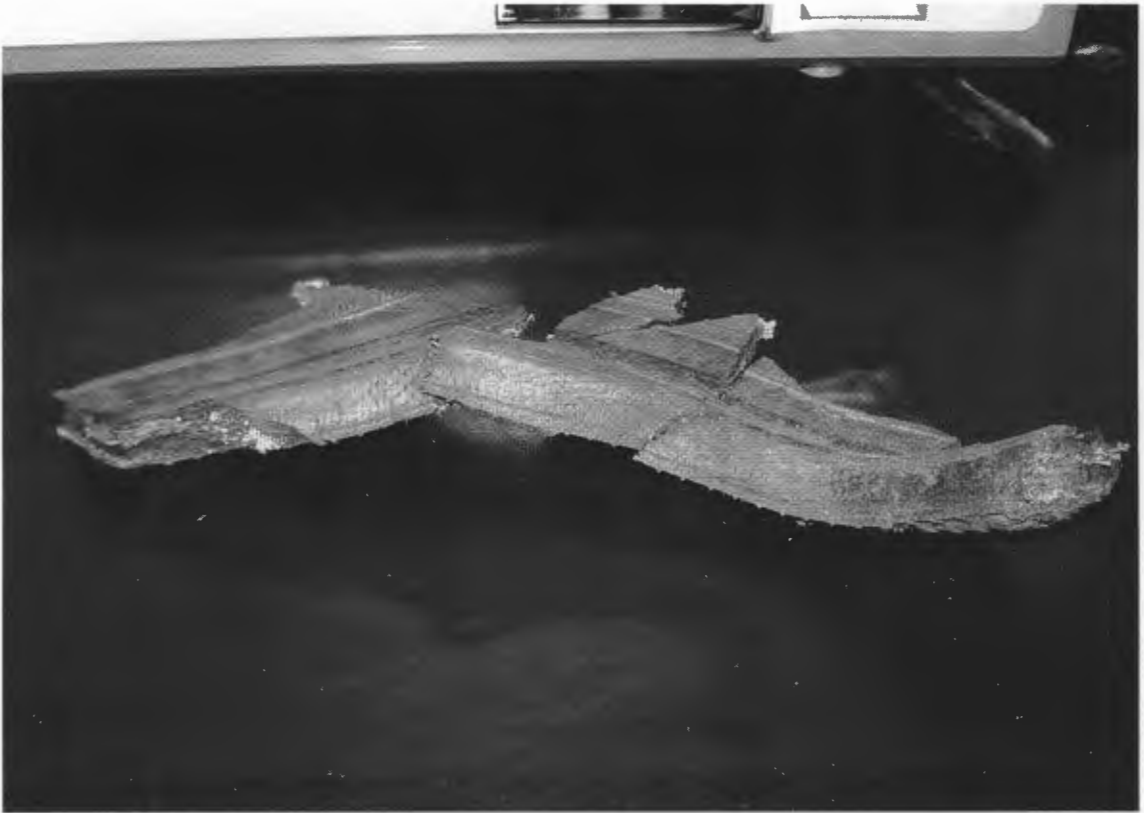

Figure 42 Photo of wire sample 2 weighed 240.51 grams no burning witnessed.

Wire sample 2 in Figure 42 exhibited no burning or smoking during each of the four 10 second heating periods. This sample had large gage bead wire through the thickest portion of its structure. This bead wire was bundled tightly together in a cord and the ends were exposed to the air but no sparking or other flame related event occurred with this sample. At the bead shoulder where the rubber was the thickest, it had high surface temperatures.

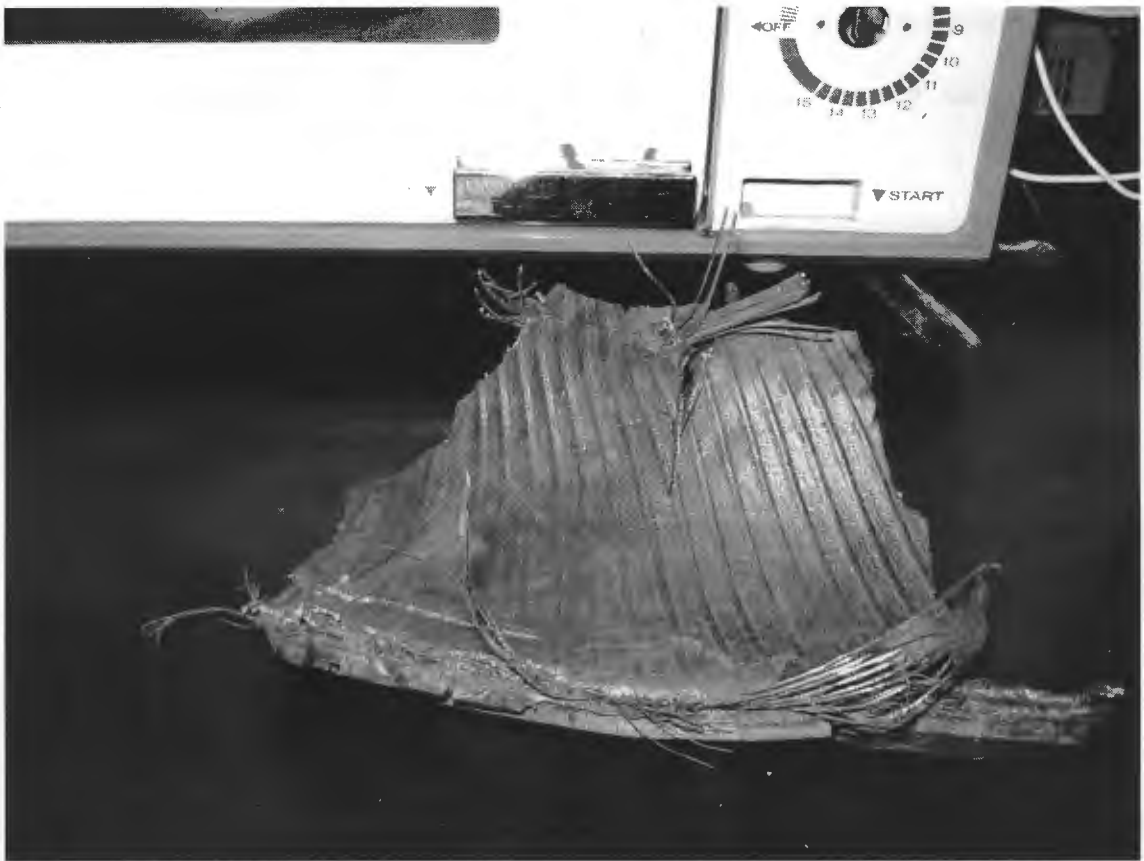

Figure 43 Photo of wire sample 3 weighed 285.13 grams with minimal flame events.

Wire sample 3 in Figure 43 was the largest sample tested. This sample has both belt and bead wire since its width encompassed the bead shoulder extending to the edge of the tread layer. Sparking was recorded between wires and some minor burning occurred at the intersection of wire and rubber. Sparking was only present when the piece passed under the waveguide where this guide enters the cook chamber. The magnetron emits a fixed power output or Watts

per cubic centimeter suggesting that this part may be close to the maximum physical size that this microwave can heat.



Figure 44 Photo of wire sample 4 weighed 27.05 grams with some burning.

Wire sample 4 in Figure 44 shows a tread layer cross section. This sample had sparking and burning events as well as melting of the thin belt wires shown in Figure 44. Similar to wire sample 1 in Figure 41, exothermic reactions ceased upon removal of magnetron emissions.

Metal in these samples created a focus for microwave energy either between wires as in Figure 44 or more commonly between wire and rubber. If the surface area was small such as existed with wire samples 1 and 4, then the power density led to an exothermic reaction within the rubber. Wire sample 2 in Figure 42 with the largest

surface area had only minor sparking and was not burned primarily due to the decreased power density the sample experienced.

Wire sample 3 in Figure 43 recorded a total lack of sparking or burning which could be attributed to the large gage bead wire being spaced approximately 2.82 mm apart which is the same diameter of the perforated holes used to light the cook chamber. These holes are sized to prevent microwave energy from escaping but large enough to allow visible light into the cavity.

CHAPTER 4

SUMMARY AND DISCUSSION

Summary of Results

Phase one has shown that as the weight of the samples increased the percent change in hardness loss increased. Far more interesting was the phenomenon of increased mass caused a corresponding decrease in energy exposure time needed to complete the trials. For instance, the minimum weight samples needed approximately 409.6 s of exposure time while the maximum weight specimens only required 66 s!

Large surface areas on low mass subjects required the most energy exposure times. Even for samples that weighed within one to two grams of each other, generally, the specimen with the largest surface area required more exposure time to complete these trials. Within a weight class, the smaller the surface area combined with the largest average thickness of specimen generally resulted in the greatest decrease in percentage of hardness values over the measured temperature range.

Figure 45 shows all eight weight groups with their change in percentage of Shore A hardness over the given temperature range. The plotted line represents the average hardness percentage change from the respective groups.

Figure 45 confirms the theory that as the weight of samples increases so does the percentage decrease in Shore A hardness values.

The lightest group 14.33g in Figure 10 was not included in Figure 45 due to its average hardness percentage value greatly exceeded the heaviest group 44.86g value. In addition, the high exposure this group required to finish the trials suggests that data obtained may have been invalid. The next heaviest group 17.17g in Figure 15 did not fit in Figure 45 since its percentage change value was higher than its mass should have allowed. Again, surface area on these low mass specimens caused an excessive amount of exposure time to complete the battery of tests.

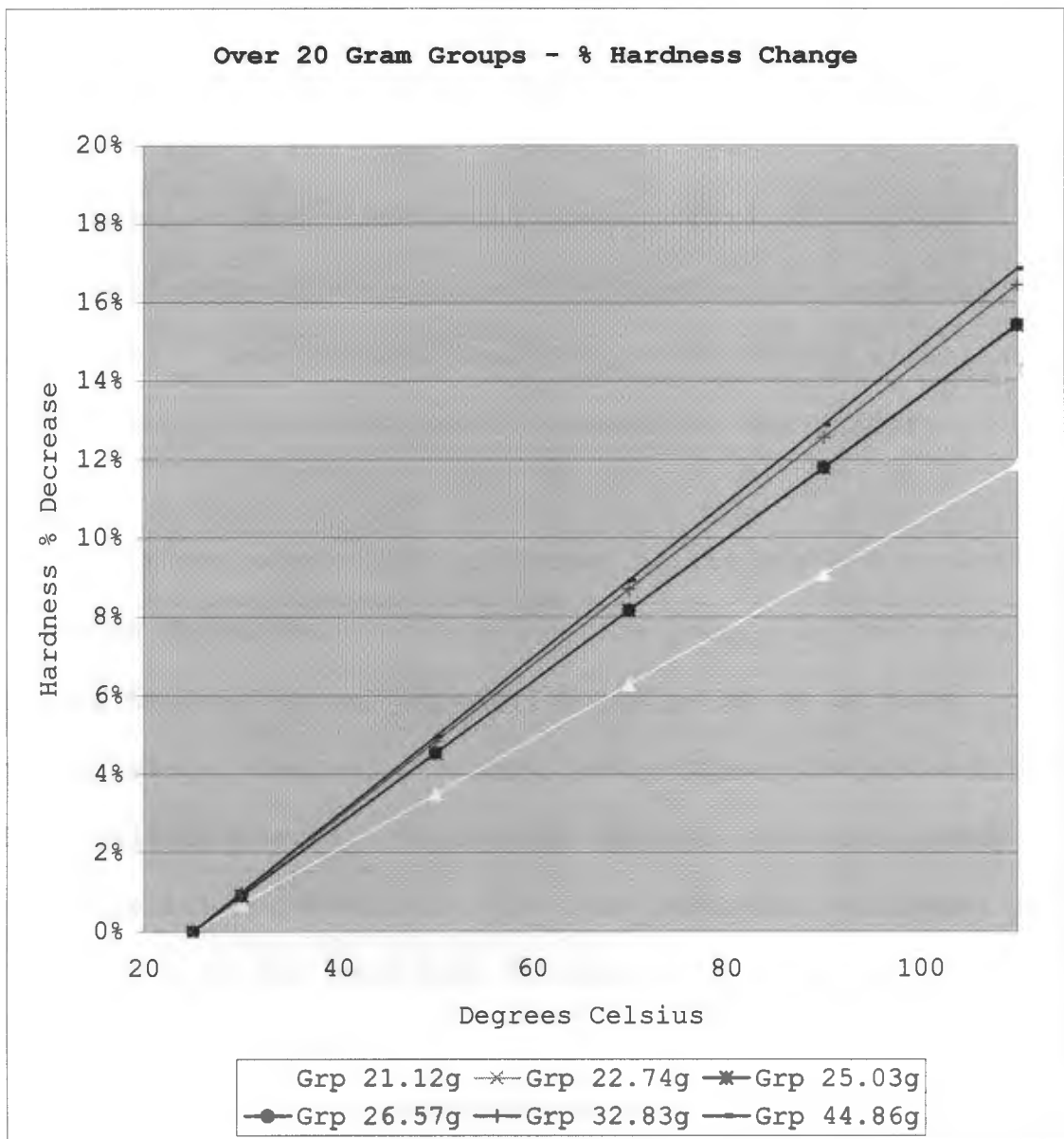

Figure 45 Composite of sample weight groups of over 20 grams hardness percent change.

Future Work and Possible Applications

The way the experiment controlled the temperature suggests that a full scale commercial prototype for processing a whole tire would have no fire or sparking events if temperature rise of the material is carefully monitored. This process would allow for energy efficient preheating of the tire prior to entering the primary crusher.

With the whole tire preheated so its surface hardness has been decreased by ten percentage points or more should enable the mechanical separation equipment to be more effective at shearing, tearing, and cutting the whole tire into smaller pieces. In theory, the now softened rubber could be cut externally by the size reduction equipment and internally by the bead wire further aiding the mechanical separation processes.

A full scale microwave preheating apparatus will need to be constructed to process whole tire singularly. This constructed chamber should have at the minimum three magnetrons and waveguides. These components could be sourced from landfills as long as they are operational. Once built, this apparatus would have a target of ten percent surface hardness reduction for the tire. This is

achievable by volumetrically heating the tire to at least 90 °C as shown in Figure 45 which is the lowest temperature to realize a ten percent reduction in shore A hardness for the majority of samples. A whole tire being uncut may require higher temperatures to reach the hardness reduction level desired.

Questions Needing Answers and Recommendations

Questions remain as to how this now softer rubber will affect the size reduction equipment.

1. Will these machines require less energy to process a softer load versus an untreated load. Are these machines going to need more knife or cutter maintenance with this softer load or does it have no effect?
2. What other process or processes would benefit from a volumetrically softened rubber?
3. Should this process be used to clean up the recyclable steel to remove the last bits of rubber still adhering to its surface?

For those brave souls who wish to continue or duplicate this experiment, the writer wishes to offer up these points:

Find an infrared sensor that can withstand microwave energy bombardment. This is essential to have a chance at closing the temperature control loop. Instead of the temperature level steps that this study followed, one could have raised the volumetric rubber temperature to 100 °C in one step and at a greatly reduced exposure time.

Larger weight and volume samples should be tested in the largest microwave oven that one can procure.

Following these suggestions would offer up a very small stepping stone toward creating a workable prototype capable of softening a whole tire or multiple tires on a continuous belt.

Conclusion

This research has proven that scrap tire rubber weighing over 20 grams will see a ten percent reduction in its Shore A hardness values when volumetrically heated to 100 °C.

Microwave energy, as used in this experiment, is very efficient at raising the temperature of scrap tire rubber to a high level in a very short period of time. Sample 15, for instance, seen a temperature rise of 65 degrees Celsius in 8 seconds. Microwave energy is efficient in that no other conventional heating process could attain that temperature rise not just on the surface but throughout the material in such a short period of time. Metal can be exposed in the microwave heated rubber but the distance must be greater than 2.82 mm between metal points. This is the approximate diameter of the holes in the cook chamber that allow lighting while the magnetron is in operation.

Finally, by using real world samples and readily available equipment, a prototype and eventually a commercial process could be pursued by the knowledge revealed in this study.

REFERENCES

- Ahmed, R., Klundert, A., & Lardinois, I. (Eds.). (1996). *RUBBER WASTE Options for Small-scale Resource Recovery* (Urban Solid Waste Series 3). Gouda, the Netherlands: WASTE co published with Tool Publications.
- Amari, T., Themelis, T.J., & Wernick, I.K. (1999). Resource recovery from used rubber tires. *Resources Policy*, 25, 179-188. Retrieved Sept. 20, 2005, from Applied Science and Technology database.
- Appleton, T.J., Colder, R.I., Kingman, S.W., Lowndes, I.S., & Read, A.G. (2005). Microwave technology for energy-efficient processing of waste. *Applied Energy*, 81, 85-113. Retrieved Oct. 14, 2005, from Science Direct database.
- ASTM International. (2003, May). *Standard Test Method for Rubber Property-Durometer Hardness (D2240-03)*. Copyright © ASTM International West Conshohocken, PA, USA: Author.
- Atwater, J.E., & Wheeler, R.R., Jr. (2004). Temperature dependent complex permittivities of graphitized carbon blacks at microwave frequencies between 0.2 and 26 GHz. *Journal of Materials Science*, 39, 151-157.
- R. W. Beck. (2005). *Analysis of New York Scrap Tire Markets* (Prepared for: New York State Department of Economic Development). New York, NY: Author.
- Bosisio, R.G., Dallaire, R., & Phromothansy, R. (1977). A Non Contact Temperature Monitor for the Automatic Control of Microwave Ovens. *Journal of Microwave Power*, 12(4), 309-317.
- Burnett, N.C. (2003). Microwave Processing of Selected Organic Wastes. In R.K. Dhir & M. Newlands (Eds.), *Recycling and reuse of waste materials: Proceedings of the International Symposium* (pp. 261-269).

California Integrated Waste Management Board (CIWMB)
(2003). *Assessment of Markets for Fiber and Steel Produced From Recycling Waste Tires*(Publication #622-03-010). Sacramento, CA: CIWMB. Retrieved from <http://www.ciwmb.ca.gov/Publications/> on Feb. 24, 2006 from Google Scholar database.

California Integrated Waste Management Board (CIWMB)
(2004). *Evaluation of Waste Tire Devulcanization Technologies*(Publication #622-04-008). Sacramento, CA: CIWMB. Retrieved from <http://www.ciwmb.ca.gov/Publications/> on Feb. 8, 2006 from Google Scholar database.

Gallawa, J.C.(2006). *The Complete Microwave Oven Service Handbook*. Retrieved from <http://www.gallawa.com/microtech/mwdanger.html> on Mar. 3, 2006 from Google Scholar database.

Ganchev, S.I., Bhattacharyya, J., Bakhtiari, S., Qaddoumi, N., Brandenburg, D., & Zoughi, R. (1994). Microwave Diagnosis of Rubber Compounds. *IEEE Transactions on Microwave Theory and Techniques*, 42(1), 18-24.

Lester, E., & Kingman, S. (2004). Effect of Microwave Heating on the Physical and Petrographic Characteristics of a U.K. Coal. *Energy & Fuels*, 18(1), 140-147.

Roussy, G., Mercier, A., Thiébaud, J.M., & Vaubourg, J.P.(1985). Temperature runaway of microwave heated materials: Study and Control. *Journal of Microwave Power*, 20(1), 47-51.

Sandoval, D. (2004). Clean-Up Crew. *Recycling Today*, 42(5), 74-79.

Yun, J., & Isayev, A. (2003). Recycling of roofing membrane rubber by ultrasonic devulcanization. *Polymer Engineering and Science*, 43(4), 809-821. Retrieved February 7, 2004, from Applied Science and Technology database.

APPENDIX A: INFRARED THERMOMETER SPECIFICATIONS AND AIMING
DIAGRAMS.

Fluke 62 Mini Specifications

Temperature Range	-30 °C to 500 °C (-20 °F to 932 °F)
Accuracy: Assumes ambient operating temperature of 23 °C ± 2 °C (73 °F ± 4 °F)	10 °C to 30 °C (50 °F to 86 °F): ± 1 °C (2 °F) Outside 10 °C to 30 °C (50 °F to 86 °F): ± 1.5 °C (3 °F) or ± 1.5 % of reading, whichever is greater. Under -10° C (14° F) ±2° C (4° F)
Response Time (95%)	<500 mSec
Spectral Response	6.5 to 18 microns
Emissivity	Preset to E=0.95
Optical Resolution (D:S)	10:1 (calculated at 80 % energy)
Repeatability	±0.5 % of reading or ≤ ±1 °C (±2 °F) whichever is greater
Ambient Operating Range	0 ° to 50 °C (32 °F to 120 °F)
Relative Humidity	90 % (±5 %) RH noncondensing @ 30 °C (86 °F)
Storage Temperature	-20 ° to 65 °C (-4 °F to 150 °F) without battery
Weight/Dimensions (with battery)	200 g (7 oz.) 152 x 102 x 38 mm (6 x 4 x 1.5 in)
Power	9 V battery
Battery Life	12 Hours
Display Resolution	0.2 °C (0.5 °F)
Display Hold	7 seconds
Standards	Conforms to EN 61326-1 Electromagnetic Emissions and Susceptibility, EN 61010-1 General Safety, EN 60825-1 Laser Safety
Laser	PDA and IEC Class II
Certifications	CE

Fluke 62 Mini Aiming Instructions

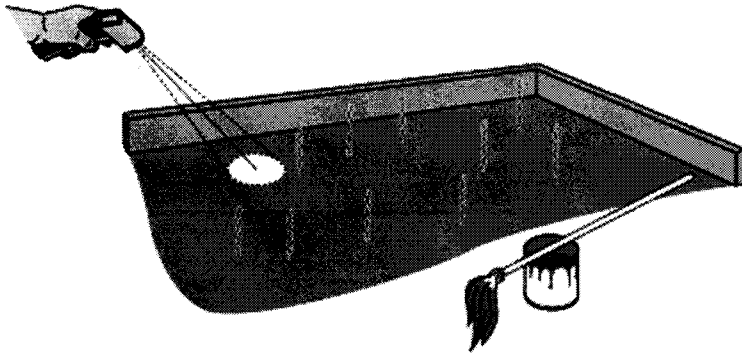
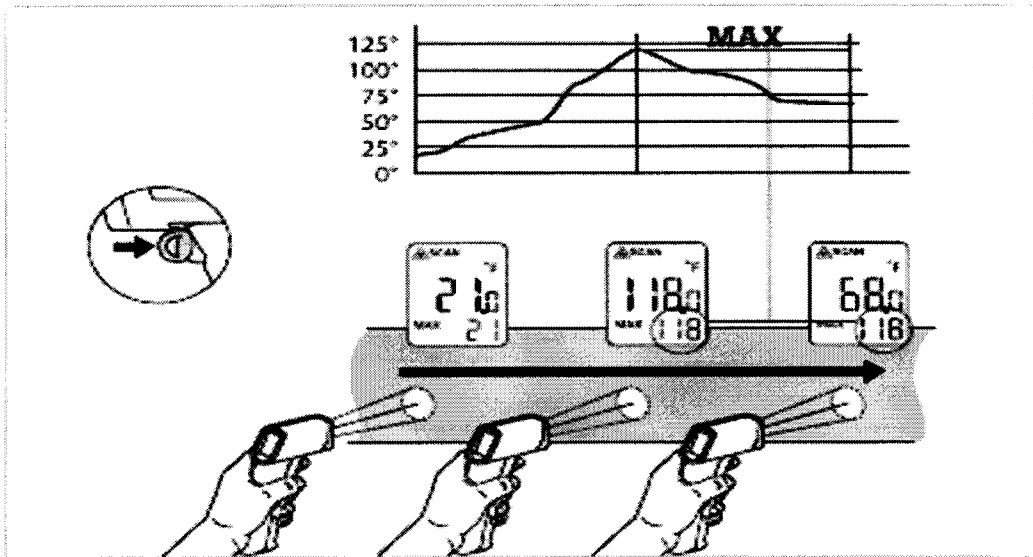

APPENDIX B: PLC PROGRAM PRINTOUT

PLC Program Printout

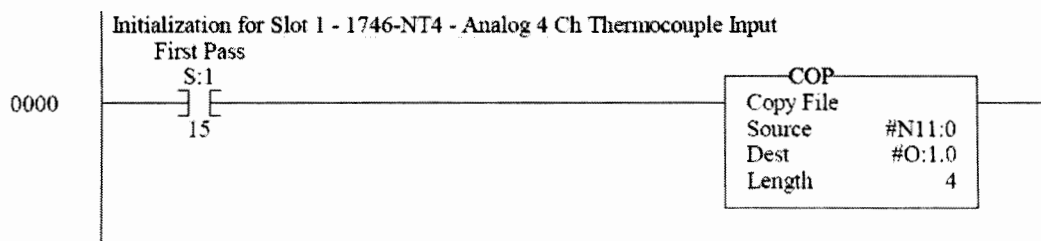

PLC Program Printout

0001

PROCESS TEMP

~~MOV~~

Move	
Source	I1.0 0<
Dest	N7:0 0<

PROCESS TEMP

~~DIV~~

Divide	
Source A	N7:0 0<
Source B	10 10<
Dest	N7:0 0<

IR PROCESS TEMP

~~MOV~~

Move	
Source	I1.1 291<
Dest	N7:1 29<

IR PROCESS TEMP

~~DIV~~

Divide	
Source A	N7:1 29<
Source B	10 10<
Dest	N7:1 29<

IR PROCESS TEMP

~~SUB~~

Subtract	
Source A	N7:1 29<
Source B	N10:1 0<
Dest	N7:1 29<

